

Key Operated Safety Interlock Switches



Safety interlock switches for the protection of hinged, sliding and lift-off guards

- Can be operated only by one of the keys provided, not by screwdrivers, fingers, etc.
- Choice of stainless steel keys: right-angle, flat, flexible and adjustable flexible
- Positive break of NC safety contacts according to BS EN60947-5-1, VDE 0660 part 206 and IEC337-1
- Available with a wide choice of contact block configurations
- Single, double and triple conduit entry types
- Heavy duty, die-cast metal alloy housing models
- Impact resistant, self-extinguishing, glass-reinforced thermoplastic housing models
- Standard and compact sizes
- Dimensions in accordance with EN50047 and EN50041
- IP65 and IP66 protection
- Conforms to BS EN60204-1 and BS EN1088
- UL and CUL approved



Options and ordering codes

1NC safety contact + 1NO auxiliary contact

FR 6 92-D	Compact size, plastic body, single conduit entry, flat key
FR 6 92-D1	Compact size, plastic body, single conduit entry, 90° key
FR 6 92-D2	Compact size, plastic body, single conduit entry, flexible key
FR 6 92-D3	Compact size, plastic body, single conduit entry, 90° key, adjustable flexible key
FD 6 93-F	Standard size, heavy duty metal body, single conduit entry, flat key
FD 6 93-F1	Standard size, heavy duty metal body, single conduit entry, 90° key
FD 6 93-F2	Standard size, heavy duty metal body, single conduit entry, flexible key
FD 6 93-F3	Standard size, heavy duty metal body, single conduit entry, adjustable flexible key
FP 6 93-F	Standard size, heavy duty plastic body, single conduit entry, flat key
FP 6 93-F1	Standard size, heavy duty plastic body, single conduit entry, 90° key
FP 6 93-F2	Standard size, heavy duty plastic body, single conduit entry, flexible key
FP 6 93-F3	Standard size, heavy duty plastic body, single conduit entry, adjustable flexible key
FL 6 93-F	Standard size, heavy duty metal body, triple conduit entry, flat key
FL 6 93-F1	Standard size, heavy duty metal body, triple conduit entry, 90° key
FL 6 93-F2	Standard size, heavy duty metal body, triple conduit entry flexible key
FL 6 93-F3	Standard size, heavy duty metal body, triple conduit entry, adjustable flexible key

For other contact block configurations, replace the 6 in the part numbers above as follows:

Replace 6 with:	Contact block configuration
9	2NC safety contacts
20	2NC safety contacts + 1NO auxiliary contact
21	3NC safety contacts
22	1NC safety contact + 2NO auxiliary contacts

e.g. FD2093F = Standard size, heavy duty metal body, single conduit entry, flat key, 2NC safety contacts + 1NO auxiliary contact

Models conform to the following standards:

Low Voltage Directive 73/23/CEE, Directive 93/68/CEE, Machinery Directive 89/392/CEE

IEC 947-5-1, BS EN60947-5-1, CEI EN60947-5-1, IEC 204, BS EN60204, BS EN418, BS EN292 UL 508, CSA C22-2 no. 14, VDE 0113, IEC 337-1, NFC 63-140, VDE 0660, BS EN1088

Positive opening of the contacts in conformity with: VDE 0660-206, IEC 947-5-1, BS EN60947-5-1, CEI EN60947-5-1

IP rating:

FR/FX: IP65
FD/FP/FL: IP66

Minimum key actuating speed 1mm/sec
Maximum key actuating speed 0.5m/sec



Key Operated Safety Interlock Switches

continued



Dimensions (mm)



Closed contact

Opened contact

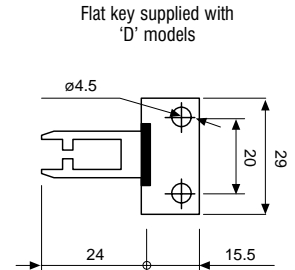
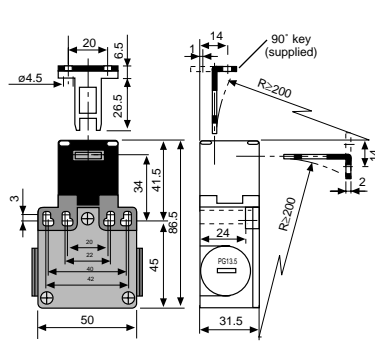
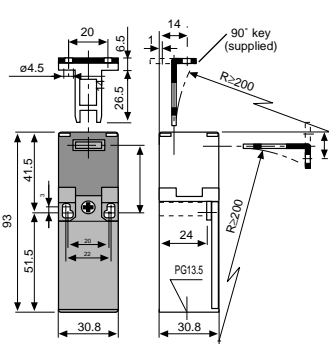

1NO	13	21		FR 692-D1	21-22	0	5	27
+ 1NC	14	22			13-14		8	

FX 692-D1	21-22	0	5	27
	13-14		8	

2NC	1	21		FR 992-D1	11-12	0	7	27
	2	22			21-22			

FX 992-D1	11-12	0	7	27
	21-22			

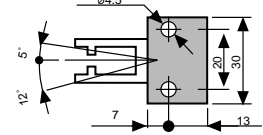
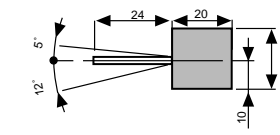
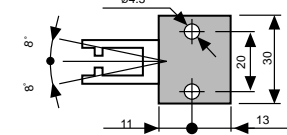
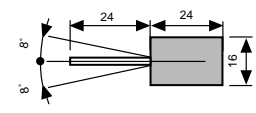

Flexible key supplied with 'D2' models. The tongue can flex in four directions for applications where the door alignment is not precise.

Adjustable, flexible key supplied with 'D3' models. The tongue can be adjusted in four directions for doors of small dimensions where the door radius is down to 80mm.



Closed contact

Opened contact

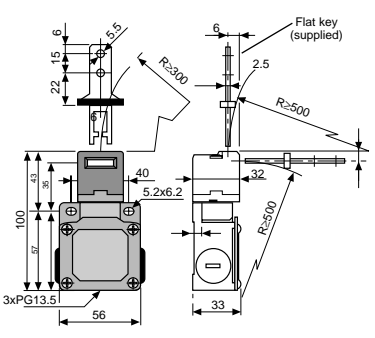
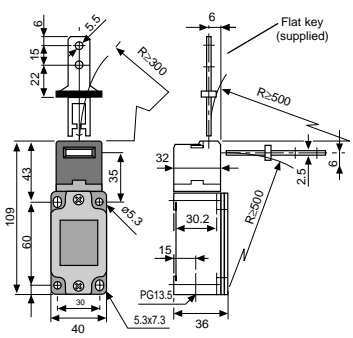

90° key supplied with 'F1' models

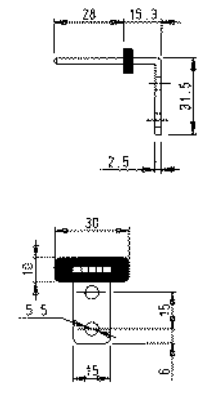

1NO	3	21		FD 693-F	21-22	0	4.5	28
+ 1NC	4	22			13-14		7	

FL 693-F	21-22	0	4.5	28
	13-14		7	

2NC	11	21		FD 993-F	11-12	0	6	28
	12	22			21-22			

FL 993-F	11-12	0	6	28
	21-22			



Closed contact

Opened contact

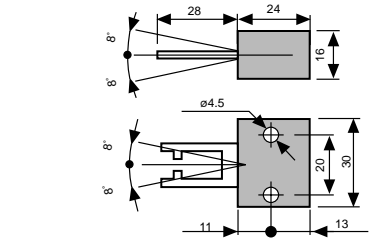
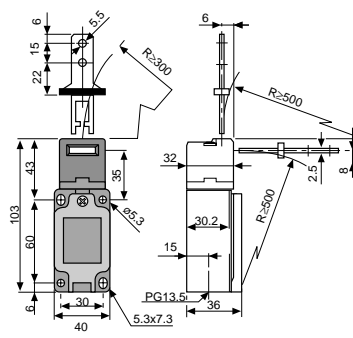

Flexible key supplied with 'F2' models. The tongue can flex in four directions for applications where the door alignment is not precise.

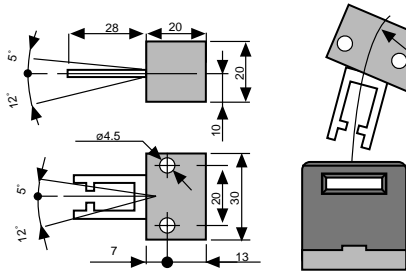

Adjustable, flexible key supplied with 'F3' models. The tongue can be adjusted in four directions for doors of small dimensions where the door radius is down to 100mm.

1NO	3	21		FP 693-F	21-22	0	4.5	28
+ 1NC	4	22			13-14		7	

2NC	1	21		FP 993-F	11-12	0	6	28
	2	22			21-22			

Key Operated Safety Interlock Switches



continued

Function

These switches have been designed to prevent tampering. In fact you can operate these switches only with the special stainless steel key provided and not with fingers or with tools, screwdrivers or pointed objects. These switches are used to control gates, doors and removable covers, which protect dangerous parts of machines. Whenever the protection is removed, the key which is fixed on it, opens the safety circuit. This ensures that the machine can only re-start when the protection is replaced.

The FR and FX models are suitable for medium duty applications and the FD, FP and FL types are manufactured from heavy gauge materials, making them suitable for heavy duty applications or harsh environments.

Terminal connections

Contact arrangement with key inserted (guard closed).

13	21		11	21		13	11	21
\overline{V}	\overline{Y}	1NO+1NC	\overline{Z}	\overline{Y}	2NC	\overline{V}	\overline{Z}	\overline{Y}
14	22		12	22		14	12	22

- The safety circuit must be connected to the NC contacts.
- Terminal screws are M3.5 with rising cable clamps for ease of wiring.
- Terminal numbering in accordance with EN50013.
- The maximum terminal screw torque is 0.8Nm (8kg cm).
- Fuse protection required against short-circuit in the safety circuit: 10A HRC quick-blow max.
- An earth terminal is provided inside the metal housings.
- Plastic housing versions are double-insulated for electrical safety.
- Contact blocks are not removable due to interlocking with the positive break system.

Head options

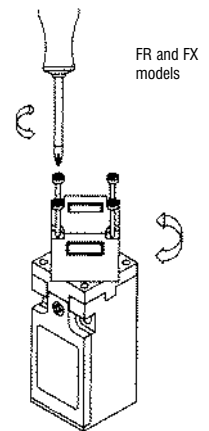
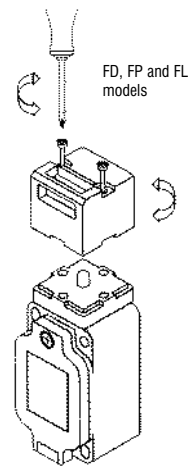

- Top and side entry points with sealing insert to cover the entry point not being used.
- Head is rotatable in 90° increments giving eight possible key-entry points; four from the top and four from the sides.
- Insert the key before rotating.
- Keys have sealing gaskets to ensure the mechanism is fully protected when the guard is closed.
- When the guard is not closed, ensure that swarf and dirt do not enter the exposed key entry point.
- Maximum head screw torque 0.8Nm (8 kg cm).
- Mechanical life of the actuator head >10⁶ operations.
- After deciding on the required head orientation, it is advisable to secure it with the tamper-proof screws which are supplied inside the switches.

Key Operated Safety Interlock Switches



continued

Applications

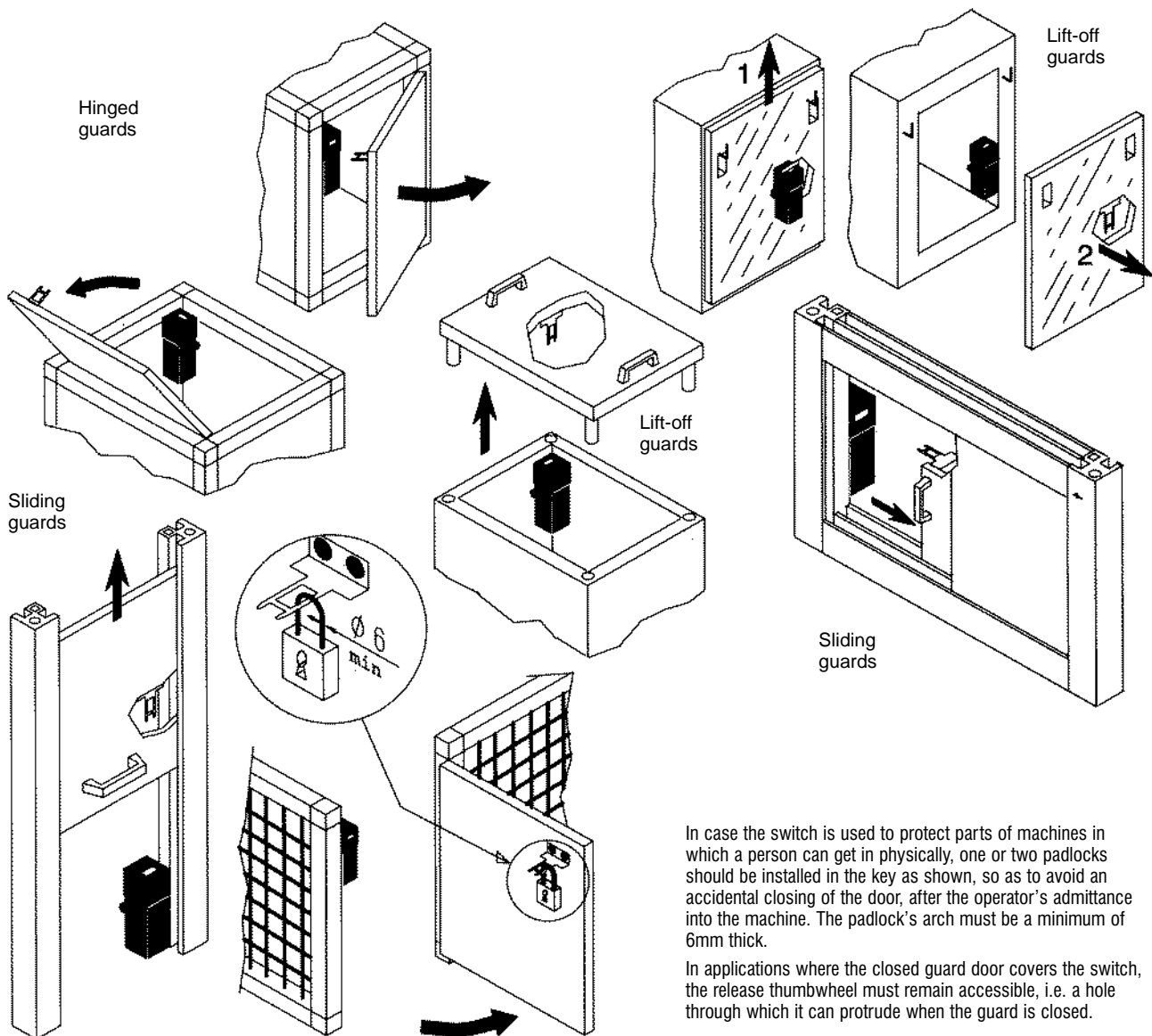

In case the switch is used to protect parts of machines in which a person can get in physically, one or two padlocks should be installed in the key as shown, so as to avoid an accidental closing of the door, after the operator's admittance into the machine. The padlock's arch must be a minimum of 6mm thick.

In applications where the closed guard door covers the switch, the release thumbwheel must remain accessible, i.e. a hole through which it can protrude when the guard is closed.

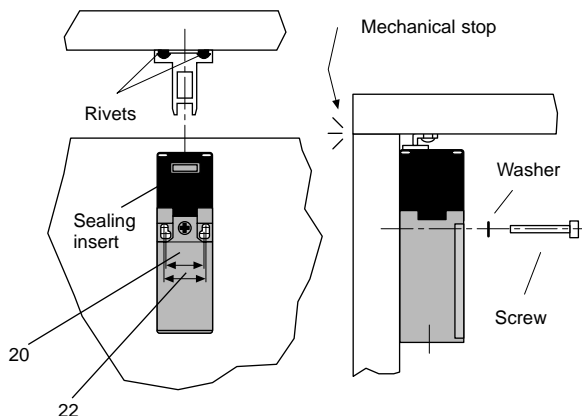

- Always use a washer under the head of the screws.
- Always place the protective sealing insert in the unused key-entry point.
- Protect the key-entry point from dirt and swarf when the guard is open.
- The switch must never be used as a mechanical end stop.
- It is recommended in BS EN1088 that the key is fixed to the moving part with rivets.
- Verify repeatedly the correct operation of the switch. That is, when the protection is removed, the machine stops and when the protection is replaced, the machine will only re-start after a manual start or reset is applied.