

NEW



5GURC_XX

TECHNIC-ACHAT
9, rue du Lugan
33130 Bègles

Tel : 05 57 99 01 72 – Fax : 05 56 87 97 66

Email : contact@technic-achat.com

Réducteur à renvoi d'angle 90° (pour moteur ZD type 5)

Caractéristiques

Vitesse	1500 tr/min
Ratio	De 3 à 180
Côte de la Bride	90mm



5 **G N** **5 0** **RH**

① ② ③ ④

①	Gearhead Frame Size	4: 80mm 5: 90mm 6: 104mm
②	Gear Type	GN Type Gear GU
③	Gear Ratio	Reduction Ratio: 50
④	Type of output shaft	
	RH: Hollow worm shaft	
	RA: Worm output shaft	
	RC: Spiral bevel hollow shaft	
		RT: Spiral bevel output shaf

Caractéristiques Réducteurs :

Le couple de sortie du réducteur dépendra du moteur en amont de ce dernier. C'est pourquoi vous trouverez ci-dessous le couple de sortie du réducteur en fonction de votre moteur.



• 40W 90mm

机型Type 电动机/减速器 Motor/Gearhead	减速比Gear Ratio		3	3.6	5	6	7.5	9	12.5	15	18	25	30	3.6	50	60	75	90	100	120	150	180		
	转速Speed r/min		50Hz	60Hz	500	417	300	250	200	166	120	100	83	60	50	417	30	25	20	16	15	12	10	8
5IK40GU-A□ 5IK40GU-E□ 5IK40GU-C□ 5IK40GU-H□ 5IK40GU-S□	5GU□RC 5GU□RT	容许力矩 Allowance Torque	50Hz		0.57	0.68	0.95	1.14	1.58	1.89	2.63	3.16	3.79	5.26	6.31	6.8	9.5	11.4	14.2	17.0	18.9	20.0	20.0	
			60Hz		0.46	0.55	0.76	0.92	1.27	1.53	2.12	2.55	3.05	4.24	5.09	5.50	7.64	9.16	11.5	13.7	15.3	18.3	20.0	20.0
			50Hz		4.67	5.61	7.79	9.35	13.0	15.6	21.6	26.0	31.2	43.3	51.9	56.1	77.9	93.5	117	140	156	187	200	200
			60Hz		4.67	5.61	7.79	9.35	13.0	15.6	21.6	26.0	31.2	43.3	51.9	56.1	77.9	93.5	117	140	156	187	200	200

5IK40GU-A/5GU□RC 5IK40GU-E/5GU□RC 5IK40GU-C/5GU□RC 5IK40GU-AT/5GU□RC 5IK40GU-ET/5GU□RC 5IK40GU-CT/5GU□RC
 5IK40GU-H/5GU□RC 5IK40GU-S/5GU□RC

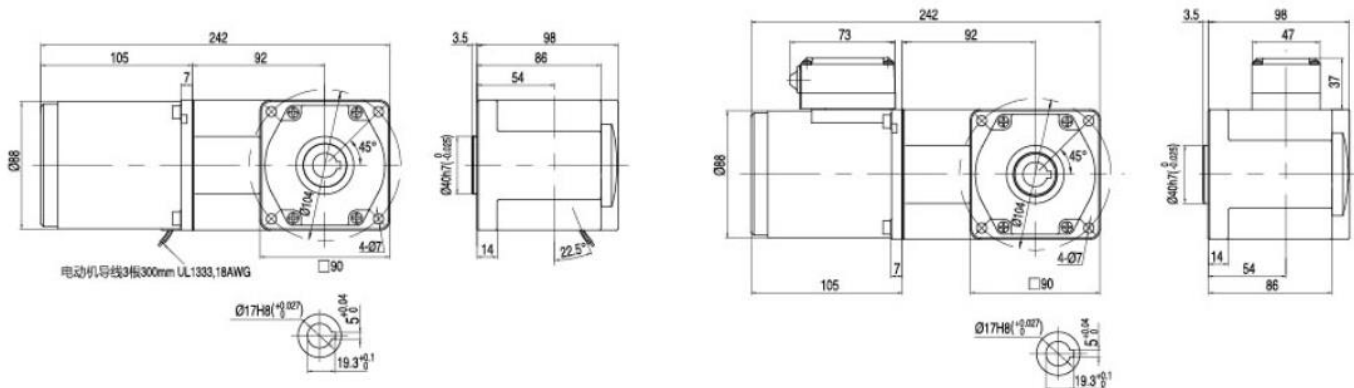

5IK40GU-A/5GU□RT
5IK40GU-H/5GU□RT

5IK40GU-E/5GU□RT
5IK40GU-S/5GU□RT

5IK40GU-C/5GU□RT

5IK40GU-AT/5GU□RT
5IK40GU-HT/5GU□RT

5IK40GU-ET/5GU□RT
5IK40GU-ST/5GU□RT

5IK40GU-CT/5GU□RT

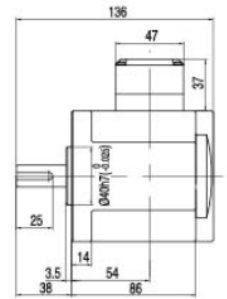
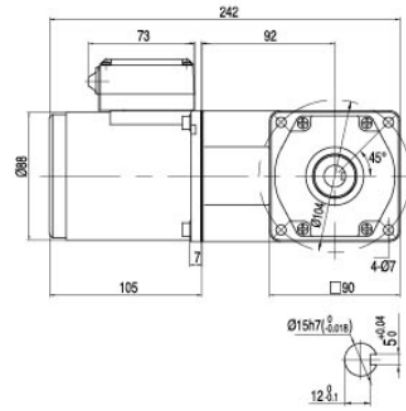
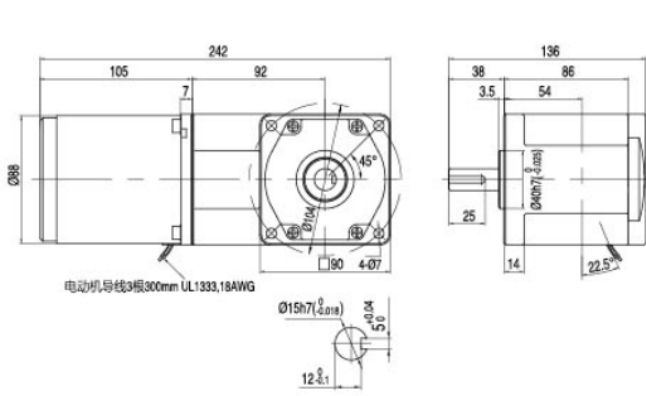

5IK40RGU-A/5GU□RC
5IK40RGU-C/5GU□RC

5IK40RGU-E/5GU□RC
5IK40RGU-H/5GU□RC

5IK40RGU-A/5GU□RT
5IK40RGU-C/5GU□RT

5IK40RGU-E/5GU□RT
5IK40RGU-H/5GU□RT

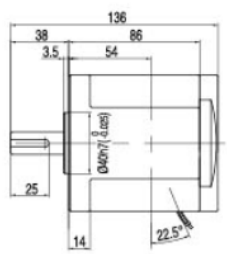
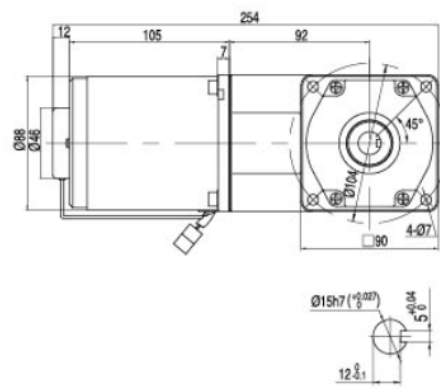
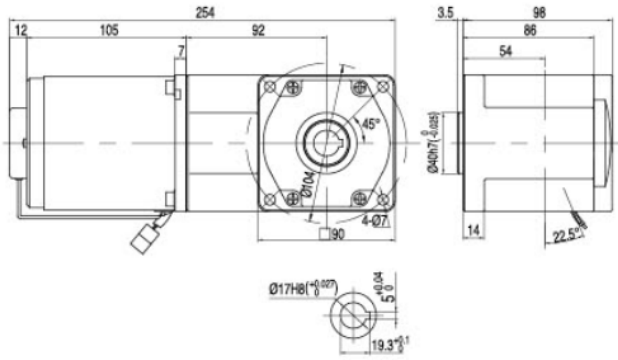

5RK40GU-AM/5GU□RC
5RK40GU-HM/5GU□RC

5RK40GU-EM/5GU□RC
5IK40GU-SM/5GU□RC

5RK40GU-CM/5GU□RC

5RK40GU-AM/5GU□RT
5RK40GU-HM/5GU□RT

5RK40GU-EM/5GU□RT
5IK40GU-SM/5GU□RT

5RK40GU-CM/5GU□RT

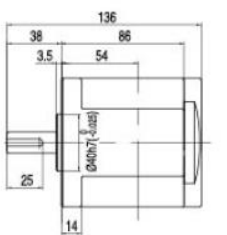
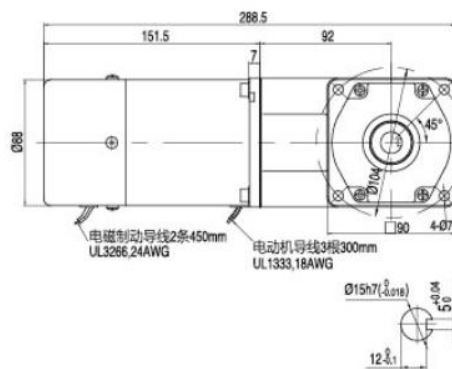
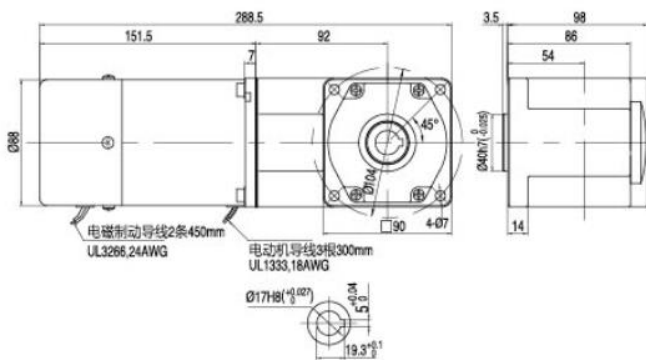

● 60W 90mm

机型Type 电动机/减速器 Motor/Gearhead	减速比Gear Ratio	3 3.6 5 6 7.5 9 12.5 15 18 25 30 3.6 50 60 75 90 100 120 150 180																						
		转速Speed r/min																						
5IK60GU-A□F 5IK60GU-E□F 5IK60GU-C□F 5IK60GU-H□F 5IK60GU-S□F	容许力矩 Allowance Torque	50Hz	5GU□RC	500	417	300	250	200	166	120	100	83	60	50	417	30	25	20	16	15	12	10	8	
			5GU□RT	600	500	360	300	240	200	144	120	100	72	60	500	36	30	24	20	18	15	12	10	
		60Hz	5GU□RC	0.85	1.02	1.42	1.70	2.37	2.84	3.95	4.73	5.68	7.89	9.47	10.2	14.2	17.0	20.0	20.0	20.0	20.0	20.0	20.0	20.0
			5GU□RT	8.70	10.4	14.5	17.4	24.2	29.0	40.3	48.3	58.0	80.5	96.6	104	145	174	200	200	200	200	200	200	200
			5GU□RC	0.69	0.82	1.15	1.37	1.91	2.29	3.18	3.82	4.58	6.36	7.64	8.25	11.5	13.7	17.2	20.0	20.0	20.0	20.0	20.0	
			5GU□RT	6.73	8.08	11.2	13.5	19.48	23.37	32.46	38.96	46.75	64.93	77.92	84.1	117	140	175	200	200	200	200	200	

5IK60GU-AF/5GU□RC 5IK60GU-EF/5GU□RC 5IK60GU-CF/5GU□RC
5IK60GU-HF/5GU□RC 5IK60GU-SF/5GU□RC

5IK60GU-ATF/5GU□RC 5IK60GU-ETF/5GU□RC 5IK60GU-CTF/5GU□RC
5IK60GU-HTF/5GU□RC 5IK60GU-STF/5GU□RC

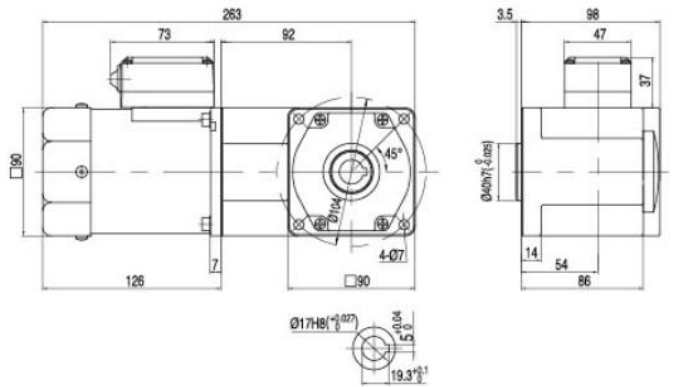
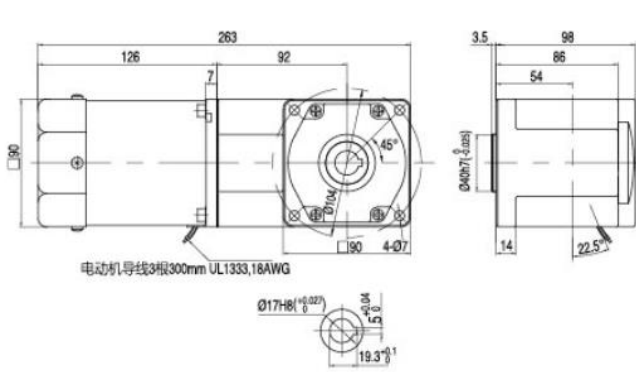

5IK60GU-AF/5GU□RT 5IK60GU-EF/5GU□RT 5IK60GU-CF/5GU□RT
5IK60GU-HF/5GU□RT 5IK60GU-SF/5GU□RT

5IK60GU-ATF/5GU□RT 5IK60GU-ETF/5GU□RT 5IK60GU-CTF/5GU□RT
5IK60GU-HTF/5GU□RT 5IK60GU-STF/5GU□RT

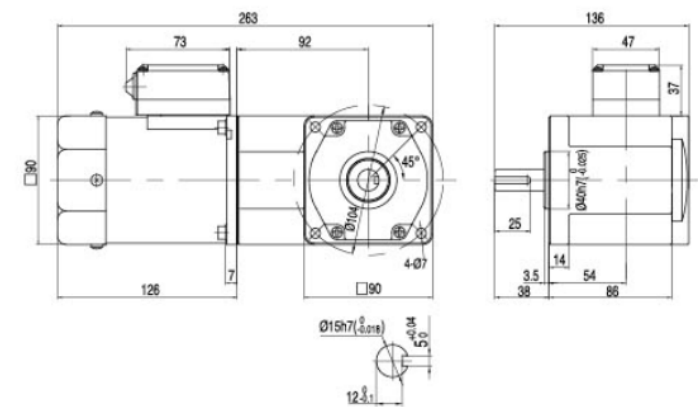
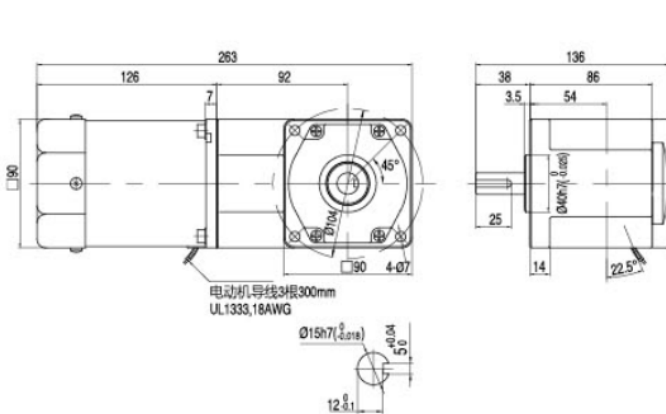

5IK60RGU-AF/5GU□RC
5IK60RGU-CF/5GU□RC

5IK60RGU-EF/5GU□RC
5IK60RGU-HF/5GU□RC

5IK60RGU-AF/5GU□RT
5IK60RGU-CF/5GU□RT

5IK60RGU-EF/5GU□RT
5IK60RGU-HF/5GU□RT

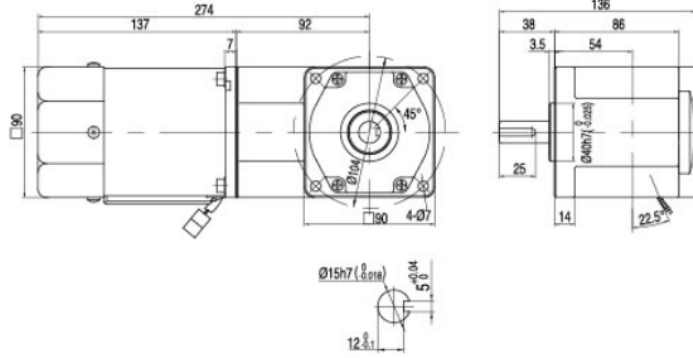
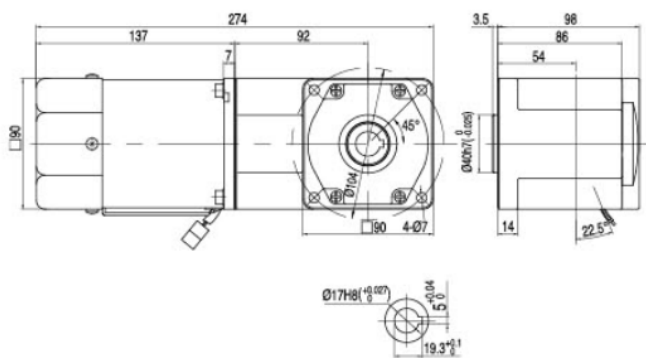

5RK60GU-AMF/5GU□RC 5RK60GU-EMF/5GU□RC 5RK60GU-CMF/5GU□RC
5RK60GU-HMF/5GU□RC 5IK60GU-SMF/5GU□RC

5RK60GU-AMF/5GU□RT 5RK60GU-EMF/5GU□RT 5RK60GU-CMF/5GU□RT
5RK60GU-HMF/5GU□RT 5IK60GU-SMF/5GU□RT

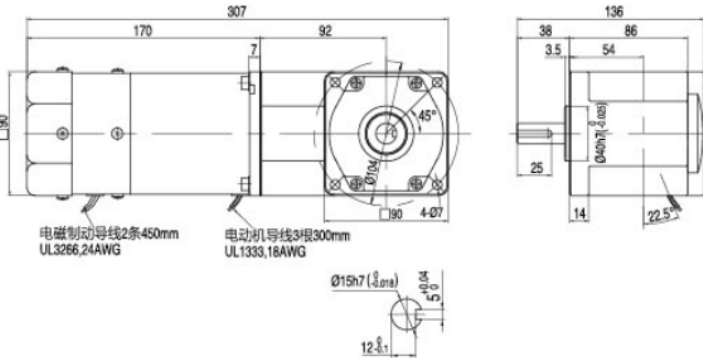
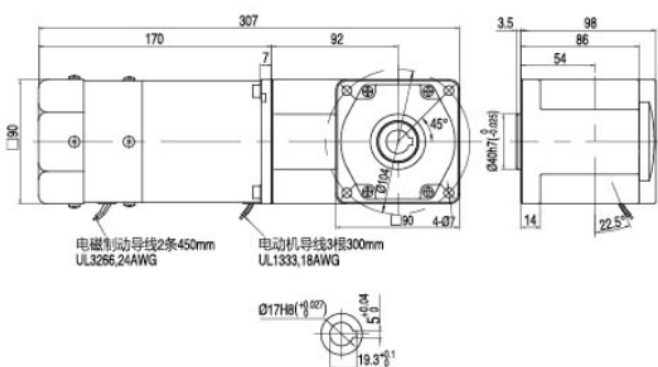

● 90W 90m

机型Type 电动机/减速器 Motor/Gearhead	减速比Gear Ratio		3	3.6	5	6	7.5	9	12.5	15	18	25	30	3.6	50	60	75	90	100	120	150	180		
	转速Speed r/min	50Hz	500	417	300	250	200	166	120	100	83	60	50	417	30	25	20	16	15	12	10	8		
5IK90GU-A□F 5IK90GU-E□F 5IK90GU-C□F 5IK90GU-H□F 5IK90GU-S□F	5GU□RC 5GU□RT	容许力矩 Allowance Torque	50Hz	1.28	1.53	2.13	2.56	3.55	4.26	5.92	7.10	8.52	11.8	14.2	15.3	20.0	20.0	20.0	20.0	20.0	20.0	20.0	20.0	
			60Hz	1.03	1.24	1.72	2.06	2.86	3.44	4.77	5.73	6.87	9.54	11.5	12.4	17.2	20.0	20.0	20.0	20.0	20.0	20.0	20.0	20.0
			60Hz	10.5	12.6	17.5	21.0	29.2	35.1	48.7	58.4	70.1	97.4	117	126	175	200	200	200	200	200	200	200	200

5RK90GU-AMF/5GU□RC 5RK90GU-EMF/5GU□RC 5RK90GU-CMF/5GU□RC
5RK90GU-HMF/5GU□RC 5IK90GU-SMF/5GU□RC

5RK90GU-AMF/5GU□RT 5RK90GU-EMF/5GU□RT 5RK90GU-CMF/5GU□RT
5RK90GU-HMF/5GU□RT 5IK90GU-SMF/5GU□RT

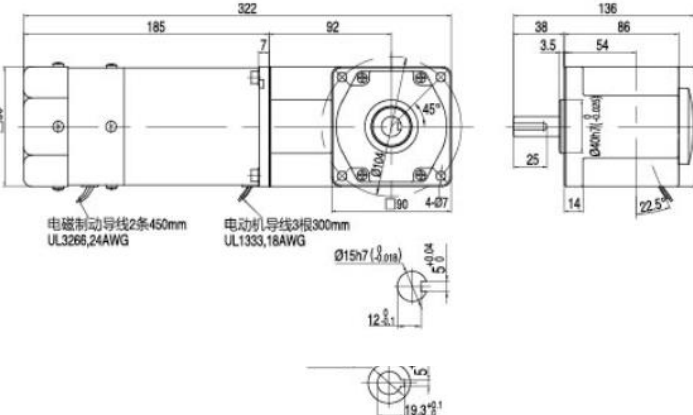
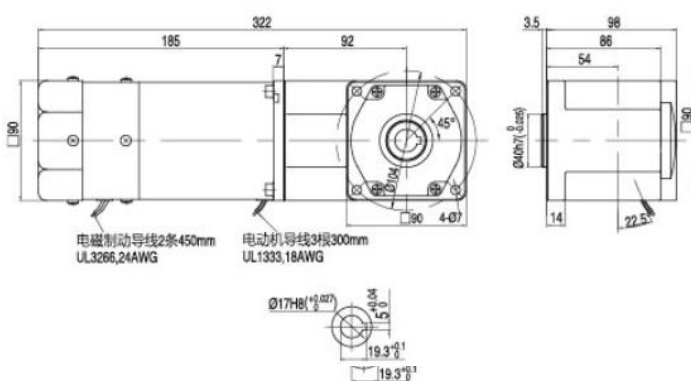

5IK120GU-AF/5GU□RC 5IK120GU-EF/5GU□RC 5IK120GU-CF/5GU□RC
 5IK120GU-HF/5GU□RC 5IK120GU-SF/5GU□RC

5IK120GU-ATF/5GU□RC 5IK120GU-ETF/5GU□RC 5IK120GU-CTF/5GU□RC
 5IK120GU-HTF/5GU□RC 5IK120GU-STF/5GU□RC

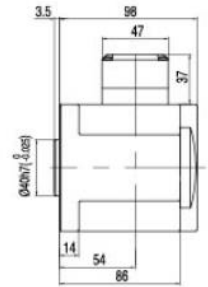
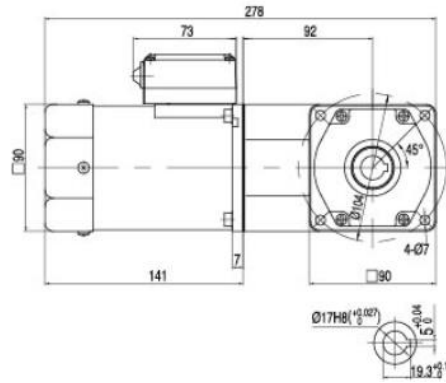
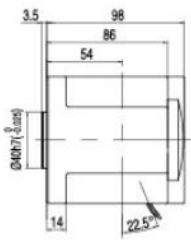
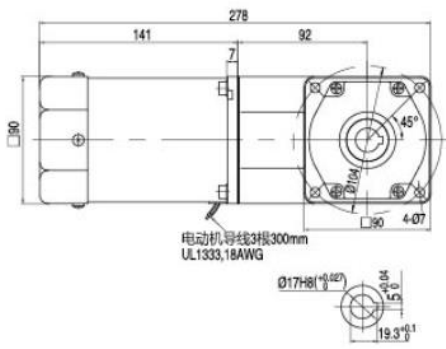

5IK120GU-AF/5GU□RT 5IK120GU-EF/5GU□RT 5IK120GU-CF/5GU□RT
 5IK120GU-HF/5GU□RT 5IK120GU-SF/5GU□RT

5IK120GU-ATF/5GU□RT 5IK120GU-ETF/5GU□RT 5IK120GU-CTF/5GU□RT
 5IK120GU-HTF/5GU□RT 5IK120GU-STF/5GU□RT

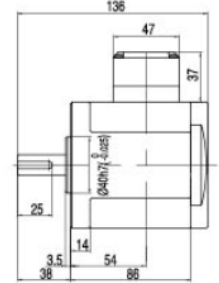
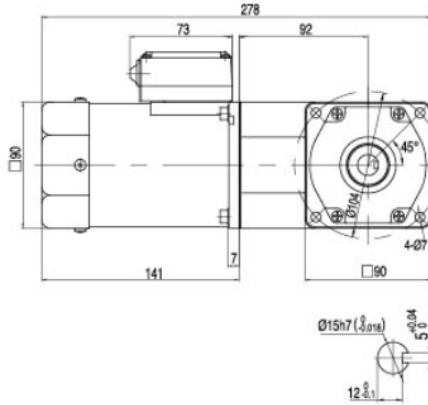
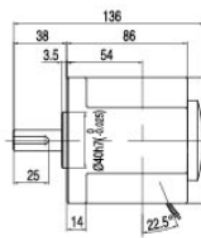
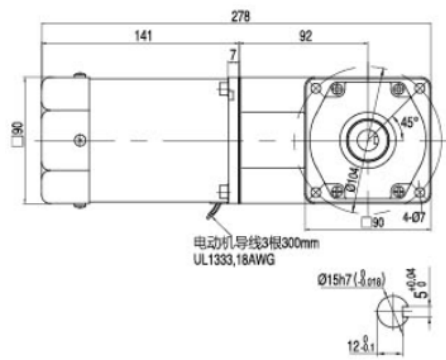

5IK120RGU-AF/5GU□RC 5IK120RGU-EF/5GU□RC
 5IK120RGU-CF/5GU□RC

5IK120RGU-EF/5GU□RC 5IK120RGU-HF/5GU□RC

5IK120RGU-AF/5GU□RT 5IK120RGU-CF/5GU□RT

5IK120RGU-EF/5GU□RT 5IK120RGU-HF/5GU□RT

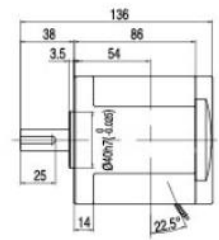
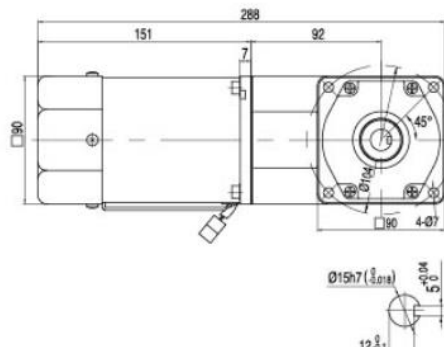
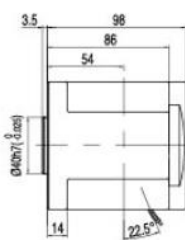
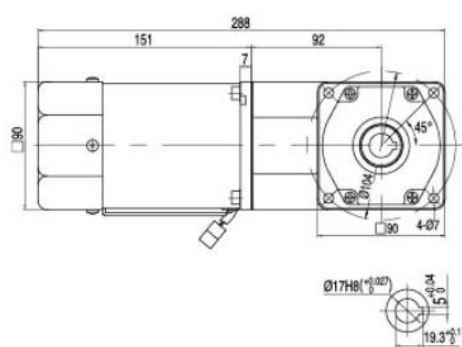

5RK120GU-AMF/5GU□RC 5RK120GU-EMF/5GU□RC 5RK120GU-CMF/5GU□RC
 5RK120GU-HMF/5GU□RC 5IK120GU-SMF/5GU□RC

5RK120GU-AMF/5GU□RT 5RK120GU-EMF/5GU□RT 5RK120GU-CMF/5GU□RT
 5RK120GU-HMF/5GU□RT 5IK120GU-SMF/5GU□RT

