

DRAWING NO \_\_\_\_\_ REV. \_\_\_\_\_

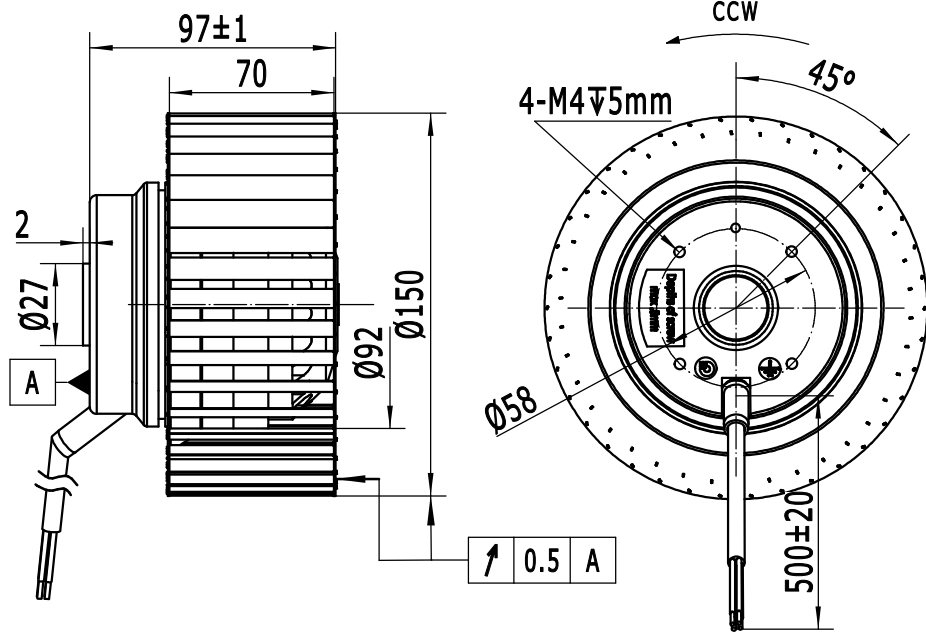

# SINGLE INLET CENTRIFUGAL FANS

Hangzhou Weiguang Electronic Co.,Ltd.

Unit: External Rotor Motor	Type:
Motor: single phase motor with capacitor	Customer:
Motor type: LXFF2E150/70-M92/35-AA01	Customer-type:

Voltage v	Frequency Hz	Input power W	Current A	Speed r/min +/-5%	capacitor µ F/ VDB
220	50	136	0.63	2650	3 µ F/450V

Insulation class : F	Operating type: S <sub>1</sub>
Permissible ambient temperature : -30℃~60℃	Temperature increase: ΔT≤75k
Motor protection:thermocontact 150±5℃	Bearings: ball bearings

Model meanings:

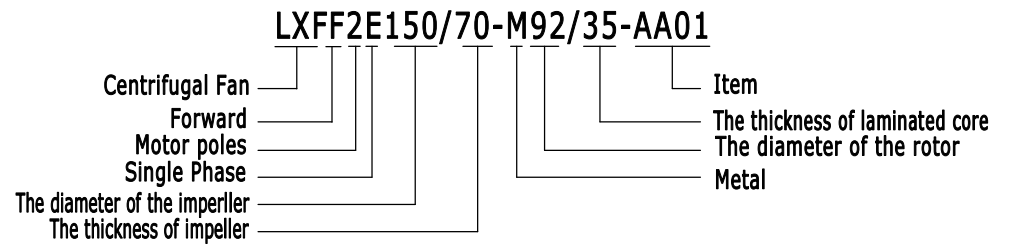

铭牌

**WEIGUANG** LXFF2E150/70-M92/35-AA01  
 220V 50Hz 0.63A 57/136W  
 2650r/min 3µF/450V CL.F IP44 XX/XX

配蜗壳曲线

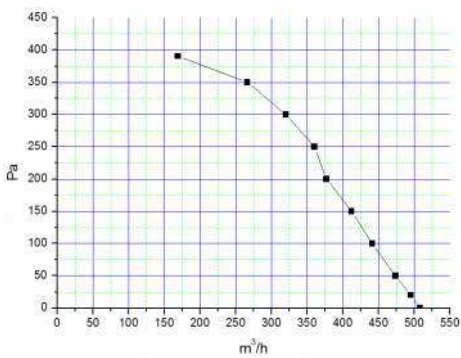

接线图

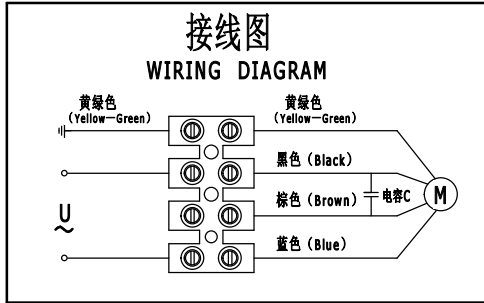

- 1、Electrical connection:RV-90,4G 0.50mm<sup>2</sup> lead wire Length 500mm .
- 2、Bearing: 608.

REV.	DESCRIPTION	APPROVED	DATE	DECIMAL	TOLERANCE	SIGN	DATE	TITLE
				X	±0.5	DRN.BY		LXFF2E150/70-M92/35-AA01
				X.X	±0.25	CHD.BY		
				X.XX	±0.15	ENG.BY		
				ANGLE	±3°	APP.BY		PROJECTION
								A4 SCALE SHEET: of