

SHR Series 180° Angular Style Air Gripper



SHR

Air gripper

SHR: Standard double acting type

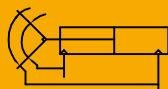

Specifications

Bore size(mm)	10	16	20	25
Action type	Double Acting			
Working medium	Clean Air(40 μ m filtration)			
Operating pressure	0.15~0.7MPa(22~100psi)(1.5~7.0bar)			
Ambient and fluid temperature(°C)	-20~80			
Lubrication	Cylinder: Not required Gripper: Fingers: grease required			
Theoretical gripping force (N.m)①	0.16	0.55	1.10	2.30
Max. operating frequency	60(C.P.M)			
Opening/Closing angle(°)	Open:180±2, Close:-2~5			
Repeatability (mm)	±0.2			
Cushion type	Rubber cushion			
Port size	M5X0.8			
Weight(g)	67	142	312	552

① The indicated gripping forces were measured at room temperature at an operating pressure of 0.5Mpa

How to Order?

Series	Bore	Magnet No.
SHR:180° Open/Close Style Air gripper	10 16 20 25	S : With magnet (Magnet is standard)

Order Example:

SHR Series 180° Open/Close Style Air gripper, Bore25, with magnet, ERP code is: SHR25-S

Product Features

1. Unique design for the opening and closing, effectively preventing foreign objects from entering
2. Special shutter used between fingers and body, reducing wearing and extending lifetime
3. 180° opening and closing type, simplify gripping and releasing, avoid workpiece motion space, wider applications
4. Built-in sensor switch groove, easy for mounting
5. Multi mounting types, convenient for using under different conditions
6. All sizes are built with magnet, easy for controlling

Optional Accessories

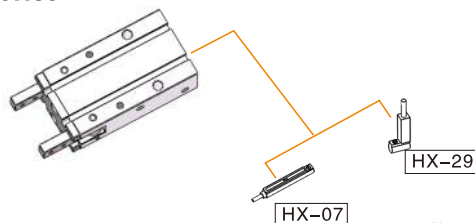

Note: For shorter stroke, due to limited space, please use HX-29

Internal Structure

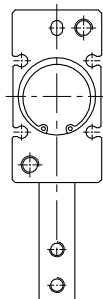
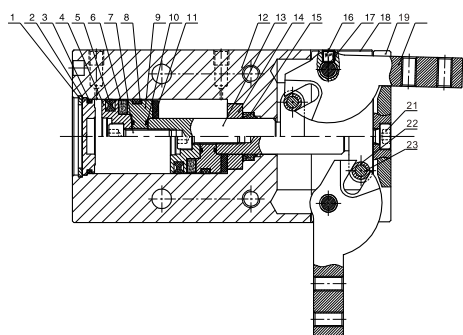

No.	Part Name	Material	No.	Part Name	Material
1	Type C retaining ring	Spring steel	13	Joint	Stainless steel
2	Rear cover	Aluminum alloy	14	Dust baffle	Brass
3	O-ring	NBR	15	Piston rod seal	NBR
4	Piston	Aluminum alloy	16	Hexagon socket set screw	Carbon steel
5	Piston seal	NBR	17	Pin	Stainless steel
6	Rutie Boron	Rutie Boron	18	Blade	Stainless steel (φ16, φ20, φ25) φ10无
7	Hexagon socket cap screw	Carbon steel (φ16, φ20, φ25) φ10 Cross recessed countersunk head screws	19	Cover plate	Aluminum alloy
8	Wear ring	PTFE	20	Gripper	Stainless steel
9	Magnet	Aluminum alloy	21	Hexagon socket cap screw	Carbon steel
10	O-ring	NBR (φ16, φ20, φ25) φ10无	22	Pin sleeve	Stainless steel (φ20, φ25) φ10, φ16无
11	Anti-bump cushion	TPU (φ10, φ16, φ20) NBR (φ25)	23	Pin	Stainless steel
12	Body	Aluminum alloy			

3

SHR

Main Dimension

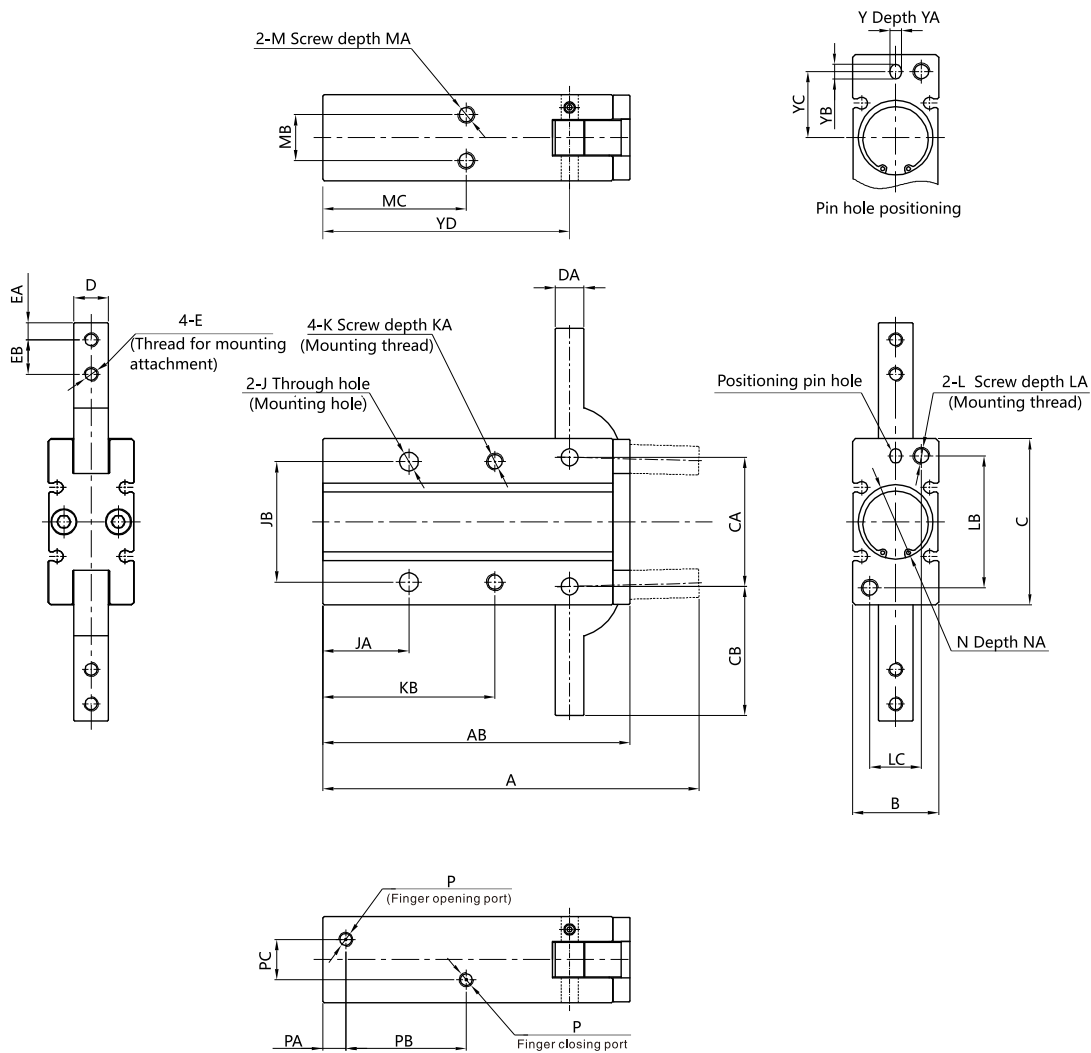

Bore/Sign	A	AB	B	C	CA	CB	D	DA	E	EA	EB	J	JA	JB	K	KA	KB	L	LA	LB	LC
SHR10	71	58	15	30	22	23.5	6	4	M3X0.5	3	6	Ø3.4	18	24	M3X0.5	6	35	M3X0.5	6	24	9
SHR16	84	69	20	38	28	28.5	8	5	M3X0.5	4	7	Ø4.5	20	30	M4X0.7	8	41	M4X0.7	8	30	12
SHR20	106	86	26	48	36	37	10	8	M4X0.7	5	9	Ø5.5	25	36	M5X0.8	10	50	M5X0.8	10	38	16
SHR25	131	107	30	58	45	45	12	10	M5X0.8	6	12	Ø6.6	30	42	M6X1.0	12	60	M6X1.0	12	46	18
Bore/Sign	M	MA	MB	MC	N	NA	P	PA	PB	PC	Y	YA	YB	YC	YD						
SHR10	M3X0.5	4	9	30	Ø11 ^{+0.05} ₀	1.7	M5X0.8	7	23	3	3 ^{+0.03} ₀	3	4	9	47.5						
SHR16	M4X0.7	5	12	33	Ø17 ^{+0.05} ₀	2	M5X0.8	7	25	8	3 ^{+0.03} ₀	3	4	15	55.5						
SHR20	M5X0.8	8	14	42	Ø21 ^{+0.05} ₀	2	M5X0.8	8	32	12	4 ^{+0.03} ₀	4	5	19	69						
SHR25	M6X1.0	10	16	50	Ø26 ^{+0.05} ₀	2	M5X0.8	8	42	14	4 ^{+0.03} ₀	4	5	23	86						

SHR Series 180° Angular Style Air Gripper



How to select product

1. Confirmation of effective gripping force

- 1.1 Although the coefficient of friction between the attachments and the workpiece differ, select a model that can provide a gripping force of 10 to 20 times the workpiece mass, or more.
- 1.2 If high acceleration, deceleration or impact forces are encountered during motion, a further margin of safety should be considered. Example) given workpiece mass: 0.05kg, gripping point L: 30mm, the pressure: 5kgf/cm² Required gripping force = 0.05 kg x 20 x 9.8 m/s² = 10 N min
Model selection: HFR16 is recommended. The gripping force is 17N, therefore satisfies a gripping force setting value of 20 times or more

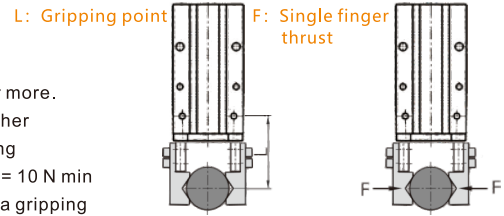

- 1.3 The effective gripping force shown in the graphs to the right is expressed as F, when both fingers and attachments are in full contact with the workpiece.

2. Connection between gripping force and gripping point distance

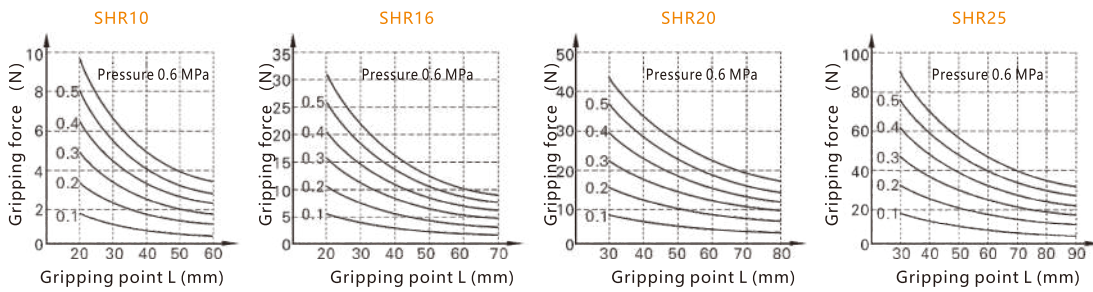

3. The selection of the gripping point

- 3.1 Workpiece should be held at a point within the range of overhanging distance (H) for a given pressure indicated in the tables below. When the workpiece is held at a point outside of the recommended range for a given pressure, it may cause adverse effect on the product life.
- 3.2 Within the allowable range of gripping point, the fixture shall be shore and light; when it is long and heavy, the inertia force when finger open and close, it will influence the performance and lifetime of the fingers at the same time.

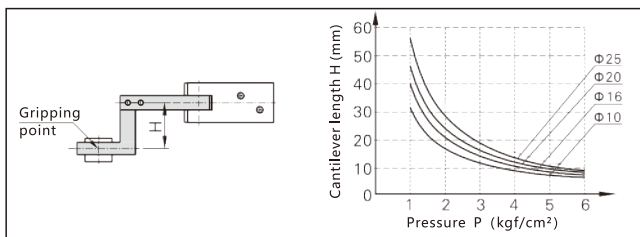

Installation and application

- Due to the abrupt changes, the pressure is low, which will lead to the decrease of the gripping force and falling of the work-pieces. In order to avoid the harm to the human body and damage to the equipment, anti-dropping device must be equipped.
- Don't use the air gripper under strong external force and impact force.
- When install and fix the air gripper, avoid falling down, collision and damage.
- When fixing the gripping jaw parts, don't twist the gripping jaw.
- There are several kinds of installation method, and the torque of fastening screw must be within the prescribed moment range shown in the below chart. If the locking moment is too large, it will cause the dysfunctional. If the locking moment is too small, it will cause the position deviation and fall.

Tail Mounting Type

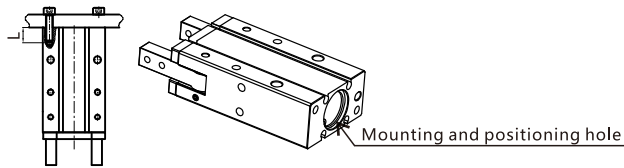

Bore	Bolt Size	Max.Locking Torque (Nm)	Max.Screwed Depth L (mm)	Tail Positioning Bore Dia(mm)	Tail positioning Depth(mm)
10	M3X0.5	1	6	φ 11	1.5
16	M4X0.7	2	8	φ 17	2
20	M5X0.8	4.5	10	φ 21	2
25	M6X1.0	7	12	φ 26	2

Mounting by front tapped hole

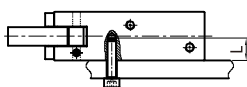

Bore	Bolt Size	Max.Locking Torque (Nm)	Max.Screwed Depth L (mm)
10	M3X0.5	0.9	6
16	M4X0.7	1.6	8
20	M5X0.8	3.3	10
25	M6X1.0	5.9	12

Mounting by front through hole

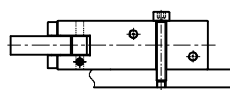

Bore	Bolt Size	Max.Locking Torque (Nm)
10	M3X0.5	1
16	M4X0.7	2
20	M5X0.8	4.5
25	M6X1.0	7

Mounting by side tapped hole

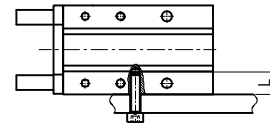

Bore	Bolt Size	Max.Locking Torque (Nm)	Max.Screwed Depth L (mm)
10	M3X0.5	0.6	4
16	M4X0.7	1.5	5
20	M5X0.8	3.5	8
25	M6X1.0	6	10

6. The installation method of the gripping jaw fittings.

When install the gripping jaw fittings, you have to pay particular attention that you can only hold the gripping jaw by using spanner, and then lock the screws with allen wrench. Never clamp the body directly and then lock the screws, otherwise the parts will be easily damaged. Please refer to below chart for the locking torque.

7. When gripping, the workpiece must be located in the center line between fingers, and the two fingers shall touch the workpiece at the same time, otherwise they could easily get broken.

8. Confirm that there is no additional external forces exerted on the fingers.

Transverse load acts on the fingers, which will cause impact load, leading to the shaking and damage of gripping jaw. Equip with gaps so that the air gripper will not crash into work-pieces and accessories at the end of its trip.

9. When workpieces inserted, the center line should be coaxial, no offset, in case there are additional external force generated on the jaw. When testing, it is specially required that the manual operation should be reduced and the pressure should be used to run it at a low speed, and guarantee the safety and no impact.

10. Please use the flow control valve to adjust the opening and closing speed of gripping jaw if too fast.

11. People cannot enter the movement path of air gripper and articles cannot be placed on the path too.

12. Before removing the air gripper, please confirm that it is out of working state, and then discharge of compressed air.

Bore	Bolt Size	Max.Locking Torque (Nm)
10	M3X0.5	0.6
16	M3X0.5	0.6
20	M4X0.7	0.8
25	M5X0.8	1.5

