



F&F Filipowski sp. j.
 Konstytynowska 79/81 95-200 Pabianice
 tel/fax (+48 42) 215 23 83; 227 09 71 POLAND
 http://www.fif.com.pl e-mail: biuro@fif.com.pl

ANALOGUE RELAY
 with current input

PA-011

WARRANTY. The F&F products are covered by a warranty of the 24 months from the date of purchase. Effective only with proof of purchase. Contact your dealer or directly with us. More information how to make a complaint can be found on the website: www.fif.com.pl/reklamacje



Do not dispose of this device in the trash along with other waste! According to the Law on Waste, electro coming from households free of charge and can give any amount to up to that end point of collection, as well as to store the occasion of the purchase of new equipment (in accordance with the principle of old-for-new, regardless of brand). Electro thrown in the trash or abandoned in nature, pose a threat to the environment and human health.

Purpose

The PA-011 device is used to convert the analog signal 0÷20 mA/4÷20 mA to the signal controlling the relay output. This allows the use of sensors with an analogue output in automation systems.

Functioning

The PA-011 device continuously measures the current signal connected to the input terminals (7-9) and on the basis of the measured value and the selected operating mode decides about the switch-on of the executive relay. The measuring input is galvanically isolated from the power supply of the device and the contacts, thanks to which it is also possible to connect PA-011 in series with other 4÷20 mA receivers.

PA-011 can operate in four different modes selected by the FUNC knob.



Confirmation of the new operating mode requires switching the power supply off and on again.

All of the available functions are described below:

Function A

The device operates in "heating" mode. The relay is switched on if the value of the input signal falls below VAL-HYST value, and it is switched off after exceeding the value set by the VAL knob.

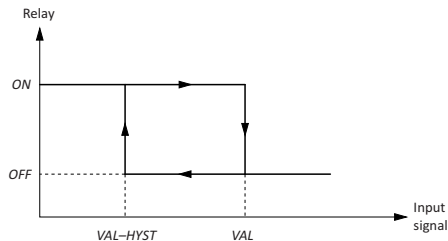

Function B

The device operates in "cooling" mode. The relay is switched on if the value of the input signal rises above the VAL + HYST value, and it is switched off if the value falls below the value set by the dial VAL.

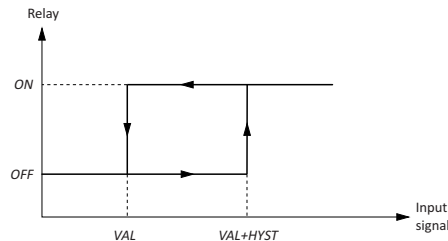

Function C

The device works in "window" mode. The relay is switched on always if the signal value is in the set window and it is switched off if the signal value is outside the set window. The width of the window is set using the HYST knob, while the window position is set using the VAL knob. For correct operation, a fixed hysteresis of 200 µA is added at the switching limit.

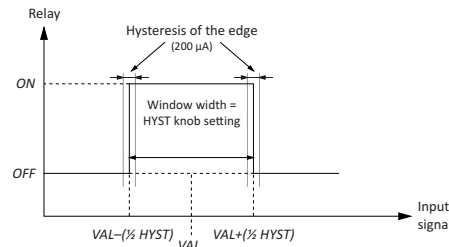

Function D

In this mode, the relay is permanently switched on. This option allows you to diagnose the correct operation of the actuator part of the device.

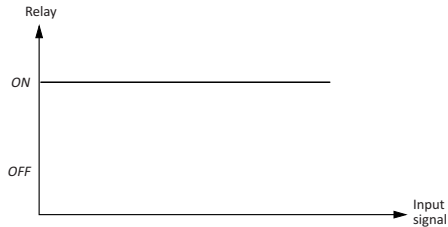

Connection diagram

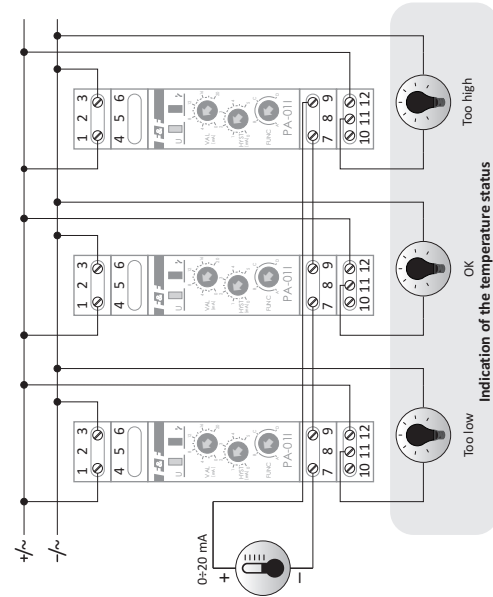
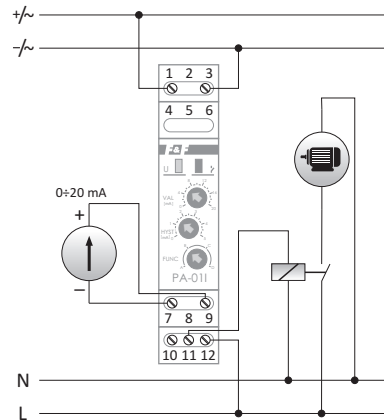

Technical data

power supply	9÷30 V DC
maximum current consumption	100 mA
range of input signals	0÷20 mA
hysteresis setting range	0÷5 mA
input resistance	150 Ω ± 0,1 %
measurement resolution	5 μA
measurement error	1 %
hysteresis in the "window" mode	200 μA
contact	separated 1×NO/NC
maximum load current	8 A
terminal	1.5 mm ² screw terminals
tightening torque	0.5 Nm
working temperature	-20÷50°C
dimensions	1 module (18 mm)
mounting	on the TH-35 rail
protection level	IP20

CE declaration

A copy of the CE declaration is available to download from the website: www.fif.com.pl from product subpage.