

Hardware Manual

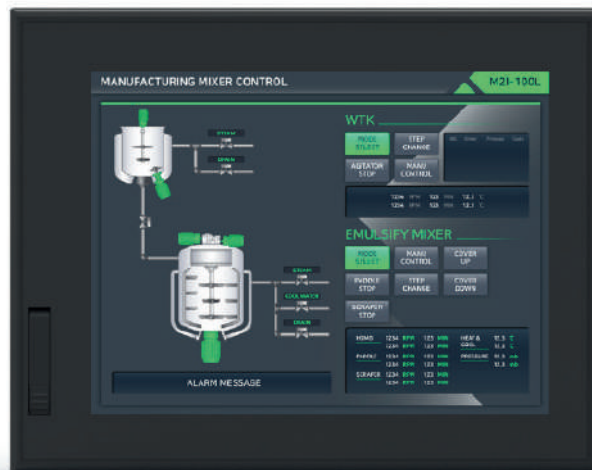

Industrial HMI Touch Panel iRis Plus Series



Thank you for purchasing the iRis HMI touch panel series from IMO Precision Controls Ltd.

Please read this manual carefully to understand the proper installation, wiring, and operation of the equipment, ensuring safe and correct use of the product.





Contents

Contents	2
Chapter 1 Safety Precautions.....	3
Chapter 2 Overview.....	5
2.1 Introduction of Products.....	5
2.2 Components.....	5
2.3 Explanation of Model Name.....	5
Chapter 3 General Specifications	6
3.1 Power Specifications.....	6
3.2 Memory Specifications.....	6
3.3 Display Specifications	6
3.4 Touch Specifications.....	6
3.5 Environment Specifications	7
3.6 Structure Specifications.....	7
Chapter 4 Part Names and General Specifications	8
4.1 IR05P-SEBP / IR08P-SEBP.....	8
4.2 IR10-SECP / IR12P-SECP / IR15P-SECP.....	10
Chapter 5 External Device Interface.....	12
5.1 Serial Communication Specifications.....	12
5.2 Ethernet Communication Specifications.....	13
5.3 USB Communication Specifications.....	14
Chapter 6 Installation	15
6.1 Installation Requirement	15
6.2 Installation Procedure.....	15
Chapter 7 Wiring	17
7.1 Power Cable Wiring.....	17
Chapter 8 Maintenance	19
8.1 Cleaning the Display	19
8.2 Periodic Check Points.....	19
8.3 Problems with the Device.....	19
8.4 Setting System Recovery Mode.....	20
Chapter 9 Products and Warning Label Location.....	21
9.1 IR05P-SEBP / IR08P-SEBP.....	21
9.2 IR10P-SECP / IR12P-SECP / IR15P-SECP	21
Chapter 10. Products Label.....	22







Chapter 1 Safety Precautions

■ Before using the product





To use the product safely and effectively, please read the contents of this manual thoroughly before use. Please follow the safety precautions to prevent accidents and potential danger from occurring. Safety precaution is classified into 'Warning' and 'Caution' and their meanings are as follows. Also, the indicated illustrations on the product and in the manual have the following meanings.

 Warning	Violating the instruction may result in serious personal injury or death.
 Caution	Violating the instruction may result in slight personal injury or product damage.
	Be cautious, for danger may be present.
	Be cautious, for there is a possibility of an electric shock.

■ General Precautions Caution

-  Do not install the product in locations where the temperature exceeds the allowable limit, as this may damage the product or shorten its lifespan.
-  Do not press the screen with hard or sharp objects (such as an awl, screwdriver, or pen), or apply excessive force. This may damage the front sheet and cause touch malfunction.
-  Do not use or store in an environment with high vibration.
-  Do not allow foreign objects such as water, liquids, or metal powders to enter the product. This may cause breakage or electric shock.
-  Do not allow water, liquids, or metal particles to come into contact with the front (screen) protective sheet, as this may affect visibility or cause touch malfunction. Use the radio or mobile phone at least 30 cm away from the main unit.
-  Up to two bright spots may appear on the LCD screen, and some areas may appear brighter. This is a normal characteristic of LCD panels and not a defect.
-  Do not store or operate in direct sunlight. Direct sunlight can change the properties of the LCD.

■ Design Precautions Warning

-  Install a protection circuit outside the product to safeguard the entire control system in case of problems with the external power supply or the product itself.
-  Product malfunctions can compromise system stability and create safety risks. To prevent this, install interlock circuits such as emergency stops, upper and lower limit switches, forward/reverse operation interlocks, and other protective safety circuits.
-  When a computer or other controllers communicate with the product, exchange data, or change its operation mode, implement a protective sequence in the PC or controller to prevent system damage due to communication errors.
-  Keep output signals and communication lines separate from power lines or high-voltage wires. Maintain a minimum distance of 100 mm (3.94 inches) between them.

■ Wiring Precautions  **Warning**

- ❗ Be sure the wiring is done correctly by checking the product’s rated voltage and the terminal layout. Incorrect wiring could result in fire, damage, or malfunctions.
- ❗ Tighten the terminal screw with the specified torque. If the screws of terminal are loose, it could result in short circuit, fire, malfunctions. FG Terminal must be used a dedicated ground. Not doing so could result in malfunctions.
- ❗ a. Grounding should meet Class 3 standards. Use a grounding cable of at least 2 mm².
- ❗ b. Position the grounding point as close to the product as possible, keeping the ground cable short.

Please see below.

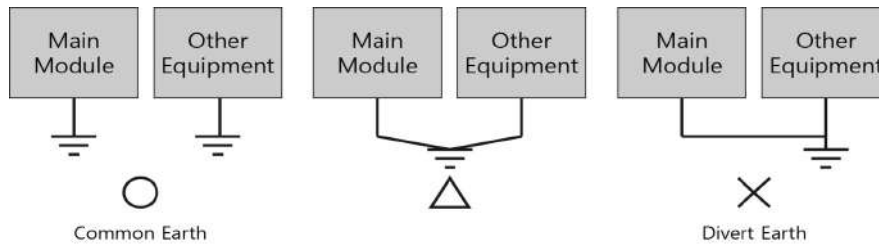

Fig. Grounding Example Diagram

■ Installation Precautions  **Caution**

- ⊘ The equipment must be used only in areas with at least Pollution Degree 2, as defined in IEC/EN 60664-1.
- ⊘ Do not install the product in locations where the temperature exceeds the specified limits, as this can damage the product or reduce its lifespan. Avoid the following environments.
 - Ambient temperatures outside the range of -10°C to 50°C.
 - Surfaces of control boards with high-pressure equipment installed.
 - Areas exposed to strong or continuous shocks or vibrations.
- ⊘ Do not store or operate the product under direct sunlight. This may damage to the quality of LCD.
- ⊘ Use the product indoors only.
- ⊘ The product is designed for use at altitudes up to 2,000 meters.

■ Disposal Precautions  **Caution**

When disposing the product or its battery, treat them as industrial waste. Improper disposal may release toxic substances or cause an explosion.

■ Cell Type Battery Specifications and Exchange  **Caution**

The battery mounted on the mainboard is not user replaceable. If the battery has reached the end of its service life, please contact our Customer Support Center for replacement and inspection.

Items	Content
Battery Voltage	DC 3 V
Battery Model	MS920SE (Lithium / Rechargeable)
Battery lifetime	Permanent (In case of ambient temperature 25 °C)

* Depending on the model specifications the above are subject to change.

- All field-wiring connections to this unit must be made from a Limited Voltage/Limited Current source, with a maximum of 24 VDC, using an isolated secondary source with an output fuse, or from a Class 2 power source.

Chapter 2 Overview





2.1 Introduction of Products

The iRis HMI touch panel is an industrial control device designed for use in industrial environments. It supports RS-232C, RS-422/485, and Ethernet interfaces, primarily for communication with other devices such as PLCs.

2.2 Components

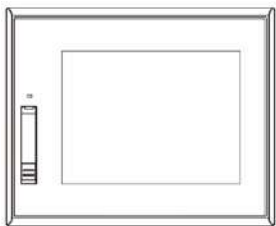
The components of the product are as follows.

Before using the product, please check that all the following components are included.

Components	Figure		Quantity
	IR05 / 08	IR10 / 12 / 15	
Product and Manual			1 each
Clamp			4
Power Connector			1
COM3 Communication Connector	Not Included		1

2.3 Explanation of Model Name

IR	□□	□	□	□	□	□
Series	Screen Size	Sub Series	Options	Ethernet	Serial	Material
iRis	05: 5.6 inch 08: 8.4 inch 10: 10 inch 12: 12.1 inch 15: 15 inch	P: Plus	S: Standard	E: Ethernet	B: 2 Ports (COM1, COM2) C: 3 Ports (COM1, COM2, COM3)	P: Plastic

Chapter 3 General Specifications

3.1 Power Specifications

Input Voltage	DC 24 V, Class 2	
Input Voltage Range	DC 20 ~ 28 V, Class 2	
Power Consumption	IR05P-SEBP	12 W
	IR08P-SEBP	
	IR10P-SECP	15 W
	IR12P-SECP	
	IR15P-SECP	
Voltage endurance	DC 24 V, within 10 ms	
Insulation Resistance	500 V DC, 10 MΩ	

3.2 Memory Specifications

Screen Memory	128 MB
Backup Memory	512 KB: System buffer (10 K Word), Including Alarm / Log / Recipe
Backup Period	Permanent
Real Time Clock	Built in (by Battery)

3.3 Display Specifications

Screen Resolution	IR05P-SEBP	VGA (640 * 480)
	IR08P-SEBP	SVGA (800 * 600)
	IR10P-SECP	
	IR12P-SECP	XGA (1024 * 768)
	IR15P-SECP	
Color	16 M Colors	
Brightness	10 Level (by software)	
Backlight	LED	
Backlight Lifetime	50,000 hours	
Display Font	MS Windows Vector font, Free Resolution Font	
Front LED Indicate	Built in	

3.4 Touch Specifications

Touch Type	Built-in, Analog resistive touch sensor
------------	---

3.5 Environment Specifications

Operation Temperature (°C)	-10 ~ +50
Storage Temperature (°C)	-20 ~ +60
Operation Humidity (%RH)	0 ~ 90 (No dew)
Atmosphere	No corrosive gas
Vibration Endurance	Amplitude: $10 \leq F < 25$ Hz (2G) X, Y, Z each direction (for 30 minutes)
Noise Immunity	1000 Vp-p (Pulse width 1 μ s)
Electrostatic Discharge	Connective discharge from EN61000-4-2: ± 4 kV
Shock Endurance	10G X, Y, Z each direction(for 3 times)
Surge Voltage	500 V (Line-Line)
Ground Connection	Class 3 (Under 100 Ω)
Protection Classification	Front IP65
Insulation Coordination	Overvoltage category II

3.6 Structure Specifications

Model Name	IR05P-SEBP	IR08P-SEBP	IR10P-SECP(-M)	IR12P-SECP(-M)	IR15-SECP
Weight (Kg)	0.62	1.06	1.68	2.18	2.78
Cooling System	Natural Air Circulation				
Case Material	Plastic				

Chapter 4 Part Names and General Specifications

4.1 IR05P-SEBP / IR08P-SEBP

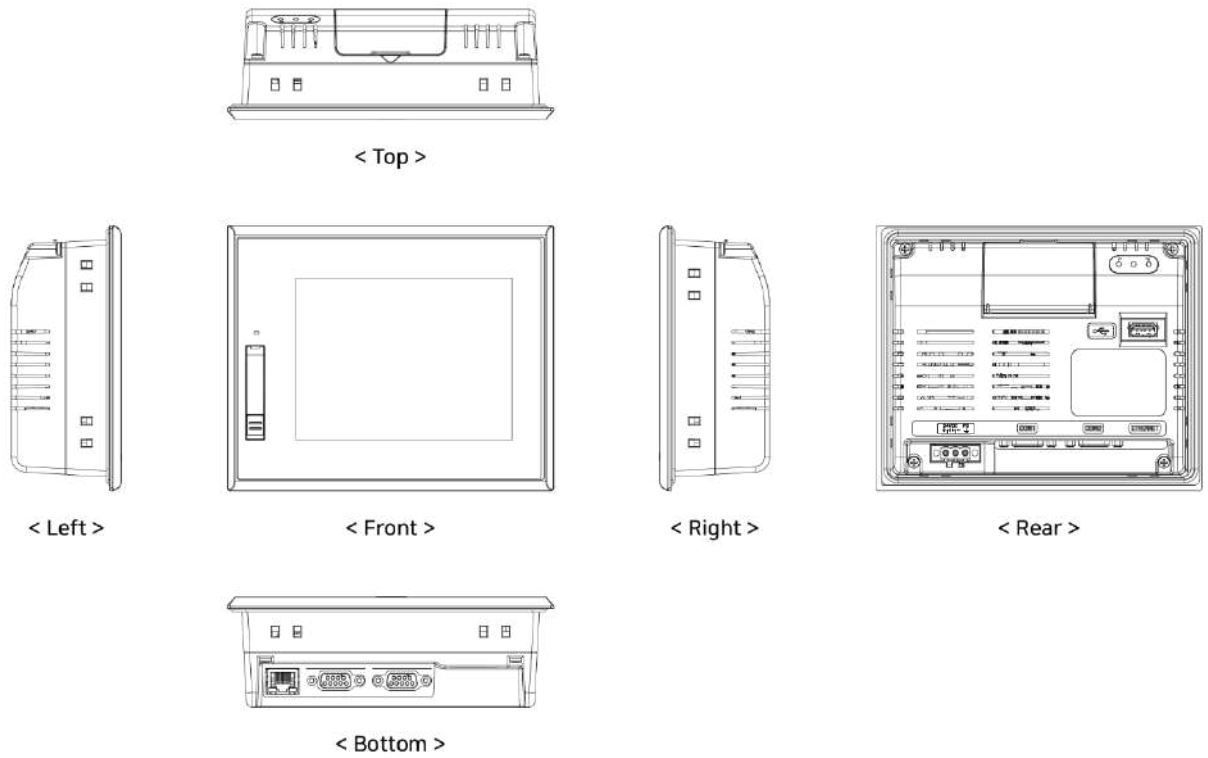

4.1.1 External Dimensions

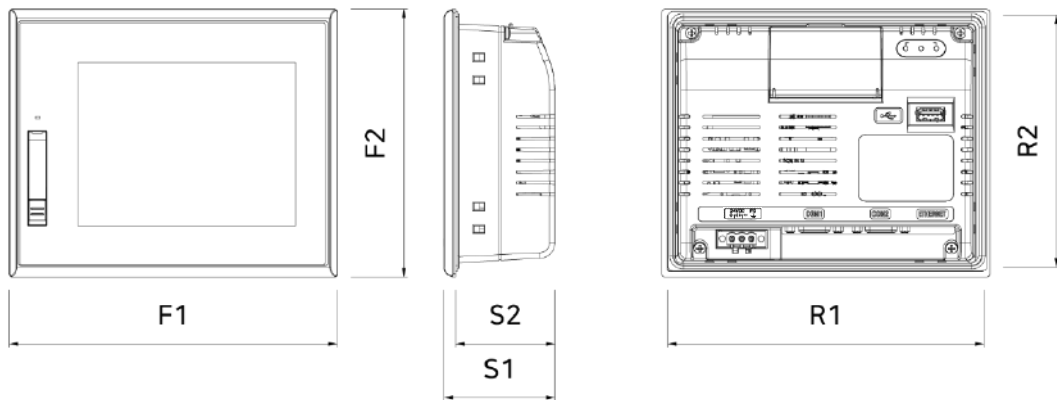

(mm)

Model	F1	F2	S1	S2	R1	R2
IR05P-SEBP	172	140	58	51	157	125
IR08P-SEBP	236	182	58.9	52.9	221	167

4.1.2 Front Panel Parts and Specifications

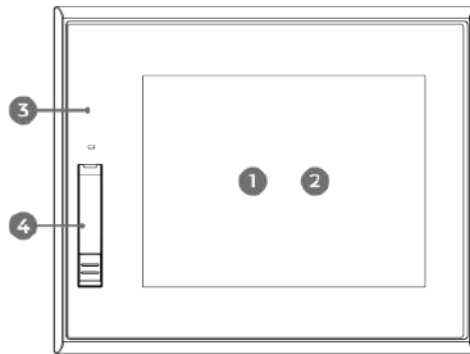

No.	Components	Description
①	LCD	TFT 16 M Color LCD
②	Touch Panel	Analog Touch
③	Front Film	Front film for moisture and dust protection
④	USB Port	USB Download/Upload Port

4.1.3 Rear Panel Parts and Specifications

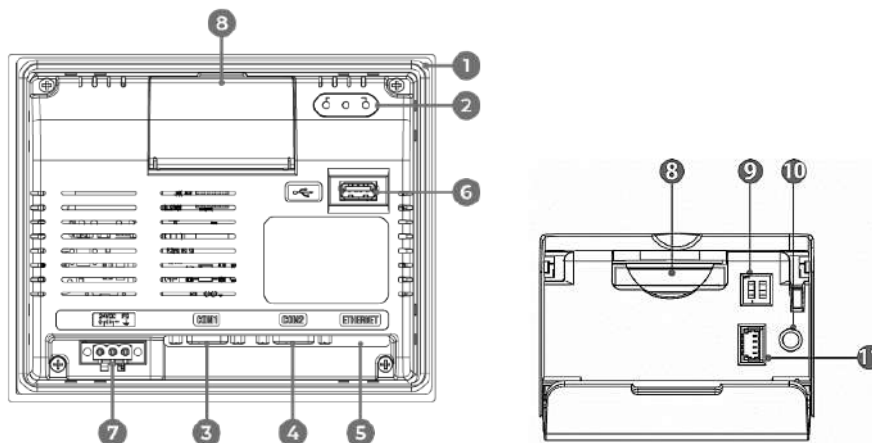

No.	Components	Type	Description
①	Rubber Packing	-	Silicone gasket for impact absorption and IP protection when mounting the unit on a wall.
②	Status LED	3	Power Status, Communication and CPU
③	COM1 Connector	D-sub 9P	RS-232C Serial Comm. with PLC
④	COM2 Connector	D-sub 9P	RS-232C / 422 / 485 Serial Comm. with PLC (Comms. Switchable Via Software)
⑤	ETHERNET Connector	RJ-45 x 1ch	10BASE-T / 100BASE-Tx, Auto-MDIX
⑥	USB Connector	Type-A x 1port	USB Connectors for Storage Options
⑦	Power Input Terminal	TB 5 mm 3P	Power Supply of Main Unit (DC 24 V)
⑧	SD Card Slot	SD Card Slot	SD Card Insert Connector (*Option)
⑨	Mode Switch	DIP Switch 2 Digit	For Recovery and Factory Reset
⑩	Reset Switch	Tact Switch	For System Reboot & Factory Reset
⑪	Diagnosis Connector	2 mm 4P	For Diagnosing the System (Manufacturer Use Only)

4.2 IR10P-SECP/ IR12P-SECP/ IR15P-SECP

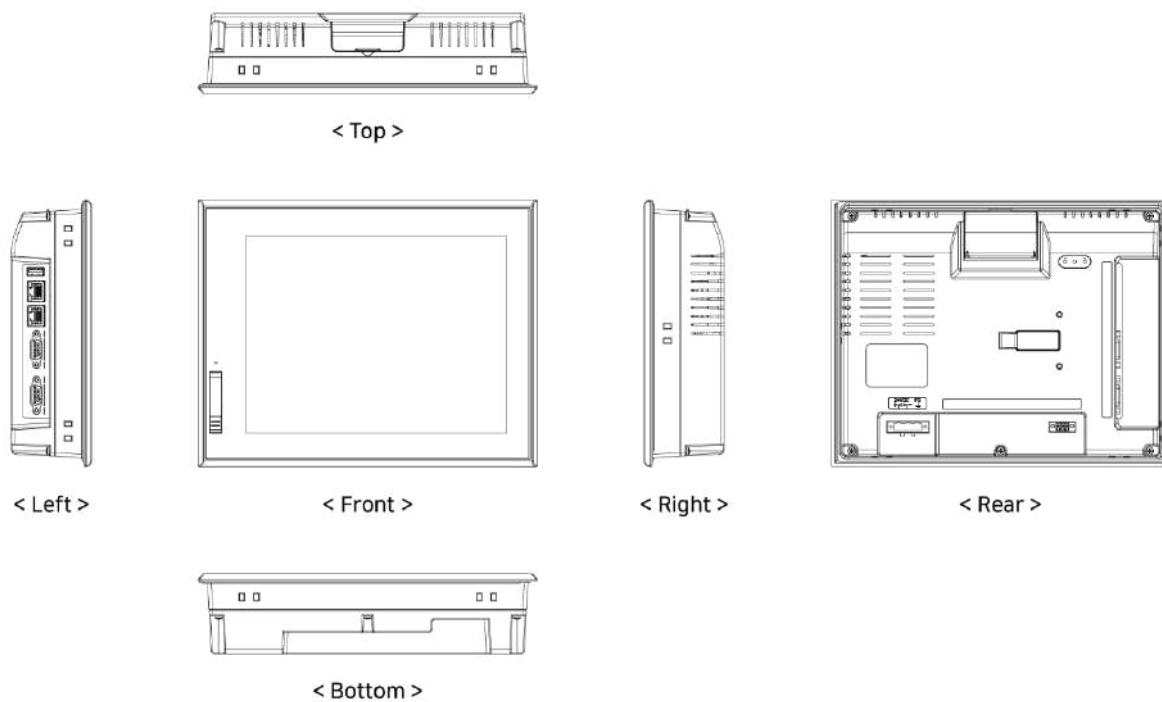

4.2.1 External Dimensions

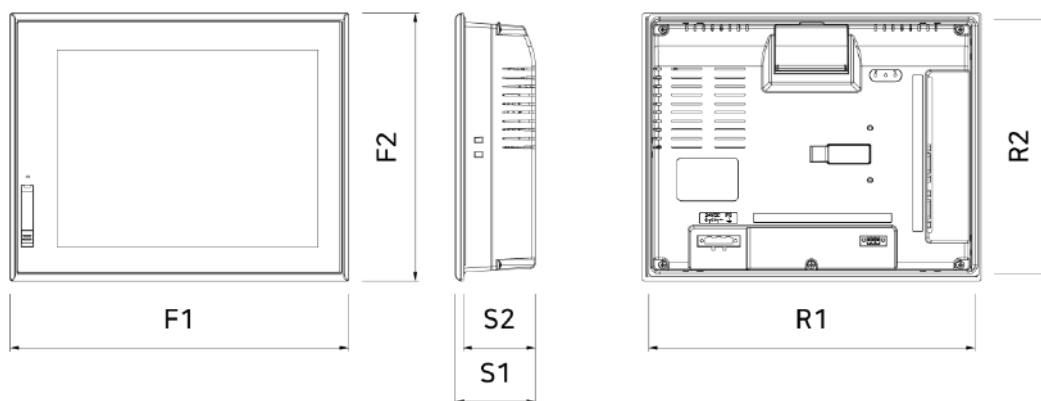

(mm)

Model	F1	F2	S1	S2	R1	R2
IR10P-SECP	212	145	45.6	39.6	196	126
IR12P-SECP	274	216	64.7	58.7	259	201
IR15P-SECP	320	261	64.7	58.7	305	246

4.2.2 Front Panel Parts and Specifications

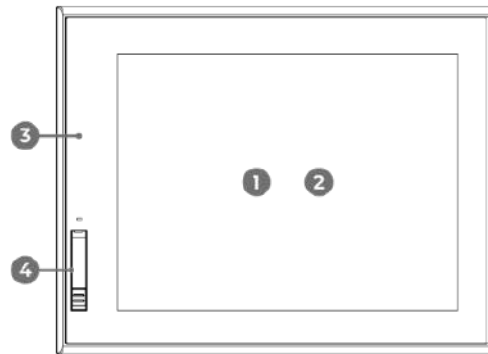

No.	Components	Description
①	LCD	TFT 16 M Color LCD
②	Touch Panel	Analog Touch
③	Front Sheet	Front film for moisture and dust protection
④	USB Port	Project Upload / Download

4.2.3 Rear Part Names and Specifications

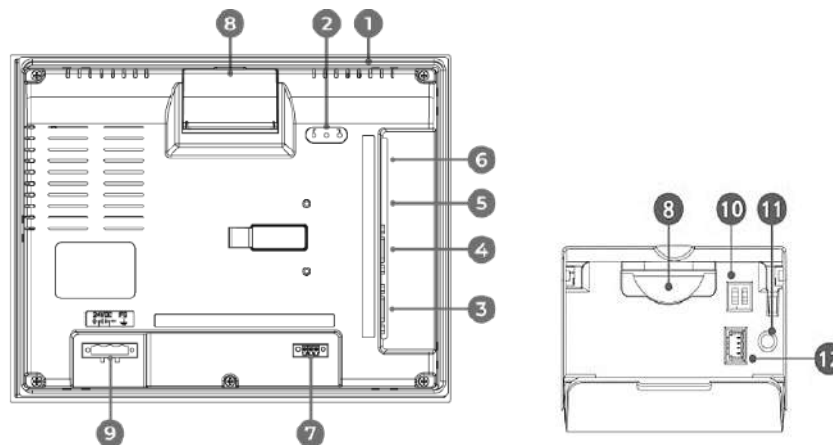

No.	Components	Type	Description
①	Rubber Packing	-	Silicone gasket for impact absorption and IP protection when mounting the unit on a wall.
②	Status LED	3	Power Status, Communication and CPU
③	COM1 Connector	D-sub 9P	RS-232C / 422 / 485 Serial Comm. with PLC (Comms. Switchable Via Software)
④	COM2 Connector	D-sub 9P	RS-232C / 422 / 485 Serial Comm. with PLC (Comms. Switchable Via Software)
⑤	ETHERNET Connector	RJ-45 x 2ch	10BASE-T / 100BASE-Tx, Auto-MDIX
⑥	USB Connector	Type-A x 1port	USB Connectors for Storage Options
⑦	COM3 Connector	TB 3.5 mm 3P	RS-485 Serial Comm. only
⑧	SD Card Slot	SD Card Slot	SD Card Insert Connector
⑨	Power Input Terminal	TB 7.6 mm 3P	Power Supply of Main Unit (DC 24 V)
⑩	Mode Switch	DIP Switch 2 Digit	For Recovery and Factory Reset
⑪	Reset Switch	Tact Switch	For System Reboot & Factory Reset
⑫	Diagnosis Connector	2 mm 4P	For Diagnosing the System (Manufacturer Use Only)

Chapter 5 External Device Interface

To enable communication between the main unit and an external device, connect the two devices as described below.

5.1 Serial Communication Specifications

5.1.1 RS-232C

Items		Specifications
Protocol		Full Duplex
Synch		Asynchronous
Communication Distance		About 15 m
Type of Connection		1:1
Control Code		ASCII Code or HEXA Code
Transmission Speed		2400, 4800, 9600, 19200, 38400, 57600, 76800, 115200, 187500 bps
Data Type	Data Bit	7, 8 bit
	Parity Bit	NONE, ODD, EVEN Parity
	Stop Bit	1, 2 bit
Modular Jack		D-sub 9 Pin

5.1.2 RS-422 / 485

Items		Specifications
Protocol		Full Duplex / Half Duplex
Synch		Asynchronous
Communication Distance		About 500 m
Type of Connection		1:N (N ≤ 31)
Control Code		ASCII Code or HEXA Code
Transmission Speed		2400, 4800, 9600, 19200, 38400, 57600, 76800, 115200, 187500 bps
Data Type	Data Bit	7, 8 bit
	Parity Bit	NONE, ODD, EVEN Parity
	Stop Bit	1, 2 bit
Modular Jack		D-sub 9 Pin

5.1.3 COM1 Connector Pinouts and Signals

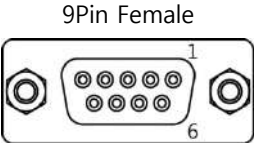
Type	Pin No.	Signal	Direction	Description
 <p>9Pin Female</p>	1	RDA (RD+)	Input	RS-422 / 485 Receive Data(+)
	2	RD (RxD)	Input	RS-232C Receive Data
	3	SD (TxD)	Output	RS-232C Send Data
	4	RDB (RD-)	Input	RS-422 / 485 Receive Data(-)
	5	SG	-	Signal Ground
	6	SDA (SD+)	Output	RS-422 / 485 Send Data(+)
	7	¹⁾ VCC	Output	+5 V, 0.2 A
	8	²⁾ VCC GND	-	Power Ground
	9	SDB (SD-)	Output	RS-422 / 485 Send Data(-)

^{1), 2)} When you need VCC for external equipment, use 7.VCC and 8.VCC GND that output is 0.2A

5.1.4 COM2 Pinouts and Signals

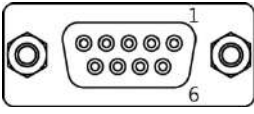
Type	Pin No.	Signal	Direction	Description
 <p>9Pin Female</p>	1	RDA (RD+)	Input	RS-422 / 485 Receive Data(+)
	2	RD (RxD)	Input	RS-232C Receive Data
	3	SD (TxD)	Output	RS-232C Send Data
	4	RDB (RD-)	Input	RS-422 / 485 Receive Data(-)
	5	SG	-	Signal Ground
	6	SDA (SD+)	Output	RS-422 / 485 Send Data(+)
	7	RTS	Output	RS-232C Request to Send
	8	CTS	Input	RS-232C Clear To Send
	9	SDB (SD-)	Output	RS-422 / 485 Send Data(-)

5.1.5 COM3 Pinouts and Signals

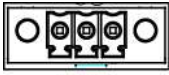
Type	Pin No.	Signal	Direction	Meaning
	1	D+	I/O	RS-485 Data(+)
	2	D-	I/O	RS-485 Data(-)
	3	SG	-	Signal Ground

* For RS-232C communication, connect RD and SD using a twisted pair cable, crossing them as shown, and connect SG directly.

* For RS-422/485 communication, use a twisted pair cable for RDA/RDB and another twisted pair for SDA/SDB.

* Do not use the shield of the communication cable as the signal ground, as this may cause communication failure.

5.2 Ethernet Communication Specifications

5.2.1 Ethernet

Items	Specifications	
Ethernet Method	IEEE 802.3i / IEEE 802.3u, 10BASE-T / 100BASE-Tx	
Speed	10M / 100Mbps	
Communication Method	baseband	
Switching Method	Auto-MDIX	
Maximum Segment Length	100 m (Product Between Hub)	
Communication Cable	UTP (Unshielded Twisted Pair)	
Modular Jack	IR05P-SEBP / IR08P-SEBP	RJ-45 x 1 ch
	IR10P-SECP(-M) / IR12P-SECP(-M) / IR15P-SECP	RJ-45 x 2 ch

5.2.2 RJ-45 Pin Layout

Type	Pin No.	Color	Signal
	1	Orange / White	TD+
	2	Orange	TD-
	3	Green / White	RD+
	4	Blue	Not Available in 10BASE-T
	5	Blue / White	Not Available in 10BASE-T
	6	Green	RD-
	7	Brown / White	Not Available in 10BASE-T
	8	Brown	Not Available in 10BASE-T

* When using a HUB, use a straight cable.

Ex) Straight cable wiring connects pins 1:1 as shown in the wiring diagram above.

* When not using a HUB and connecting devices directly, use a cross cable.

Ex) In cross cable wiring, TD+ and RD+ are swapped, and TD- and RD- are exchanged as shown in the wiring diagram.

5.3 USB Communication Specifications

5.3.1 USB Host

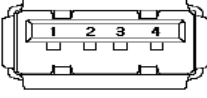
Type	Items	Specifications
	USB Interface	EHCI / OHCI Specification Version 1.0, USB 2.0 / 1.1 Compatible
	Communication Method	Control / Bulk
	Transfer Speed	Max. 480 Mb/s
	Support Device	USB Storage (FAT16 / FAT32 File Format Available)
	Connector Type	USB Type-A x 1 port

5.3.2 USB OTG

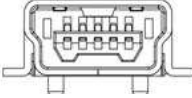
Type	Items	Specifications
	USB Interface	USB 2.0
	Communication Method	Interrupt / Bulk / Isochronous
	Transfer Speed	Max. 480 Mb/s
	Supporting OS	Windows 98SE / 2000 / XP / VISTA / 7 / 10 (32 / 64bit)
	Cable Length	Recommended: 3 m cable (manufacturer). Use ≤ 1.5 m if purchased separately.
	Connect Type	USB Mini-B (Female) x 1 port
	Connect Method	Connect Via USB Front of Display Module

Chapter 6 Installation Warning

6.1 Installation Requirement

- (1) Install the product within the temperature range of -10 to 50 °C and humidity range of 10–90 % RH. Operating outside these limits may cause screen damage, malfunction, or product failure.
- (2) Ensure that heat from surrounding equipment does not cause the product to exceed its specified operating temperature
- (3) To minimize external mechanical hazards, control the mechanical risks in the surrounding environment.

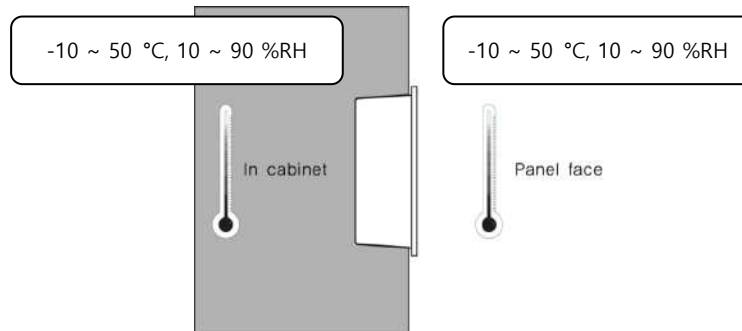

6.2 Installation Procedure Warning

To install this product, please follow the following procedure.

6.2.1 Panel Cut

Cut the panel where the product will be mounted and insert the product from the front side.

(1) The Size of Panel Cut

Prepare the panel cut according to the mounting dimensions specified for each iRis Standard series model in the table below before installation.

1) IR05P-SEBP / IR08P-SEBP

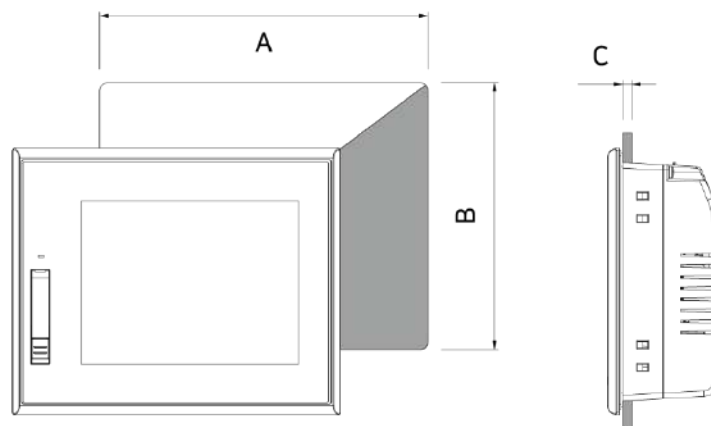

2) IR10P-SECP/ IR12P-SECP/ IR15P-SECP

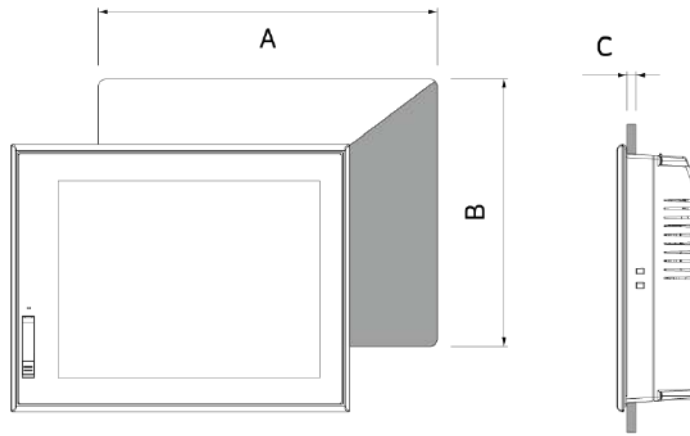

(mm)

Model	A	B	C
IR05P-SEBP	158 (+1.0 / 0)	125 (+1.0 / 0)	1 ~ 5
IR08P-SEBP	222 (+1.0 / 0)	168 (+1.0 / 0)	
IR10P-SECP	260 (+1.0 / 0)	202 (+1.0 / 0)	
IR12P-SECP	306 (+1.0 / 0)	247 (+1.0 / 0)	
IR15P-SECP	355 (+1.0 / 0)	286 (+1.0 / 0)	

(2) Clamp Fixing  Warning

Clamps for this product should be installed as shown below to ensure the device maintains its IP protection performance.

a) Insert the clamp into the slot of the product.

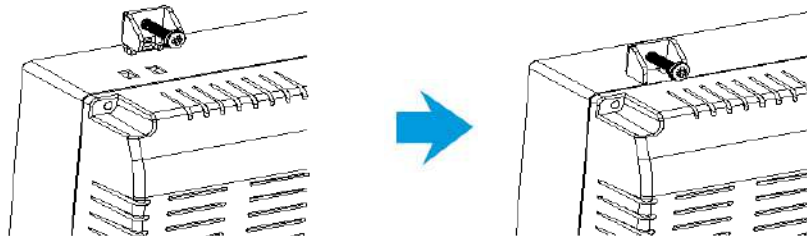

b) Screw the unit into the panel cut with a screwdriver.

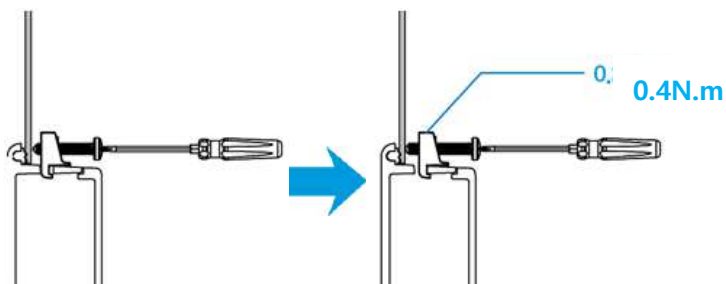



Do not overtighten the screws, as this may deform the front panel and cause the touch sensor to malfunction. Tighten the screws to a torque of 0.2 Nm.

Chapter 7 Wiring Warning

7.1 Power Cable Wiring Warning

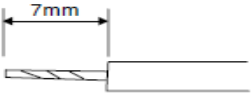
(1) The Power cable should have the following specification.  Warning

Power Cable Specification	0.75 ~ 2.5 mm ² (18 ~ 13 AWG)
F.G Cable Specification	Over 2 mm ² (14 AWG)
Conductor Type	Simple or Standard Wire
Bolt tightening torque	0.6 N.m  Warning
Conductor Length	
Temperature rating of the field installed conductors	65 °C

(2) The Power terminal should have the following specification.  Warning

To Prevent wearing of cable and to enhance transmission, please use a pin type conductor for power cable and ground wiring.

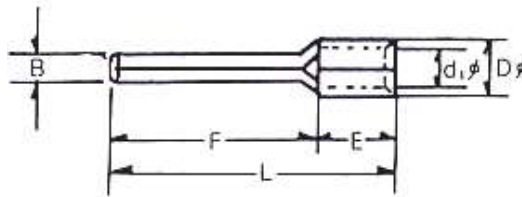

(mm)

B	L	F	E	D	d
1.8 ~ 2.0	14 ~ 22	8 ~ 14	5	3.3 ~ 3.8	2 ~ 2.5

(3) Wiring of power cable is as follows.  Warning

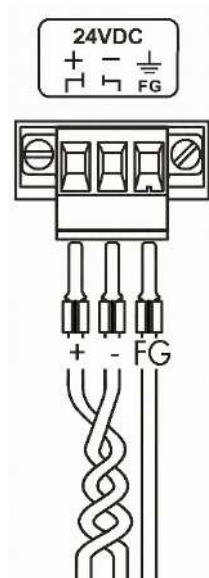

7.2 Ground Wiring Warning

- (1) The product is designed with sufficient anti-noise measures, but grounding is especially important in environments with high electrical noise. Follow the instructions below when grounding.
- (2) Use an exclusive ground. The ground should meet Class 3 standards, with a ground resistance of less than 100 Ω .
- (3) If an exclusive ground cannot be provided, a shared/common ground may be used, as shown in Figure B.

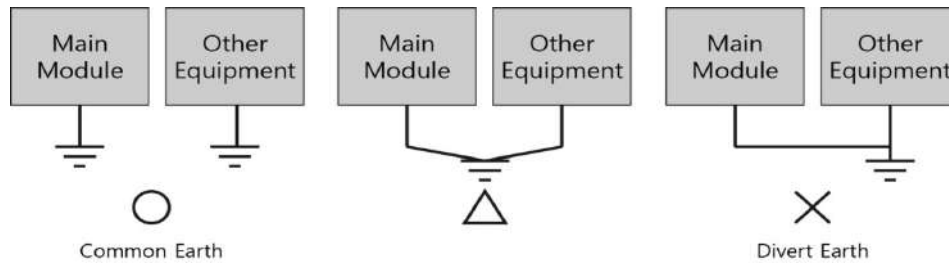

Fig. Grounding Example Diagram

- (4) Use a grounding cable with a cross-section of at least 2 mm². Place the grounding point as close to the product as possible and keep the ground line as short as possible.

Chapter 8 Maintenance Warning

8.1 Cleaning the Display

When the surface or frame of the display become dirty, spray the cleaning solution onto a soft cloth and wipe the device. Do not spray the cleaning solution directly onto the device.

8.2 Periodic Check Points

Check the followings periodically for best condition of the device.

(1) Environment

- a. Is the operating temperature within the allowable range (-10 ~ 50 °C)?
- b. Is the operating humidity within the allowable range (10 ~ 90 %RH)?
- c. Is the surrounding environment free of corrosive gases?

(2) Power

- a. Is the input voltage within specifications?

(3) Related Items

- a. Visually check the LCD backlight to ensure it is functioning properly.
- b. Visually inspect the touchpad for any damage, scratches, or contamination.

8.3 Problems with the Device Warning

- (1) If a problem occurs during operation, stop using the product immediately and IMO Precision Controls as indicated on the product label.
- (2) Only authorized personnel from IMO Precision Controls are permitted to inspect or repair malfunctions.
- (3) If the issue cannot be resolved on-site, the equipment may be collected and returned to IMO Precision Controls.
- (4) The manufacturer is not responsible for any damage or malfunction caused by usage conditions that exceed the installation and operation standards described in the manual.
- (5) In environments with high electromagnetic noise, attach ferrite cores to the main power and field cables, as power and communication cables may be affected by noise.
- (6) If a USB device malfunctions due to noise, place ferrite cores on both ends of the cable to improve noise resistance.

8.4 Setting System Recovery Mode

- (1) If the system fails to boot normally due to a problem during operation, the built-in recovery function can be used to maintain the factory default state. Please note that the built-in project will be deleted when using the recovery mode.
- (2) After opening the rear cover, you can adjust the setting switch. Keep the "Normal" state when booting normally. If the system is recovering, turn off the power and set it to "Factory Reset".
- (3) When the recovery is completed, the buzzer sounds, then turn off the power and reset to "Normal" state.

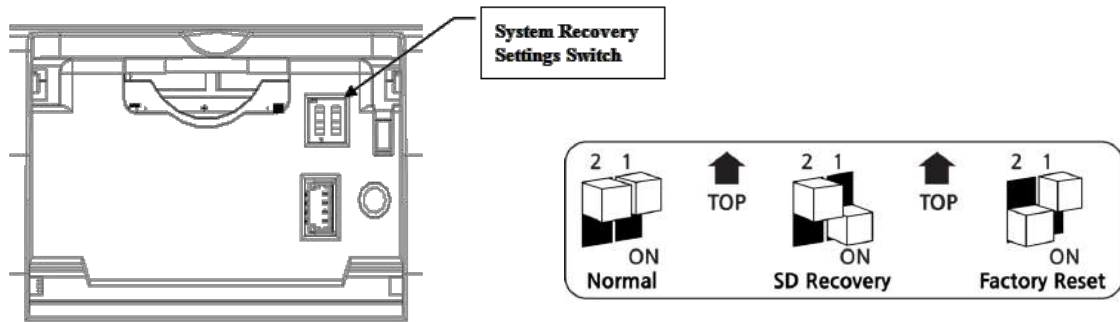

Chapter 9 Products and Warning Label Location

9.1 IR05P-SEBP / IR08P-SEBP

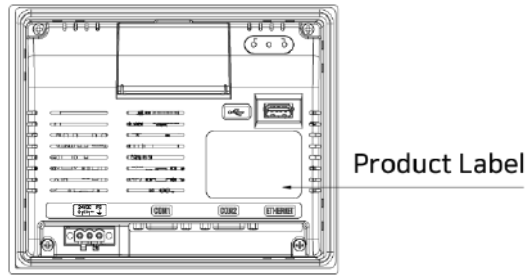

9.2 IR10P-SECP/ IR12P-SECP/ IR15P-SECP

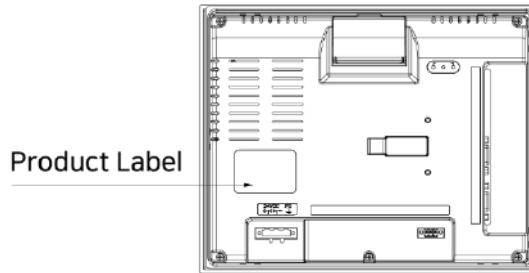

Chapter 10. Products Label

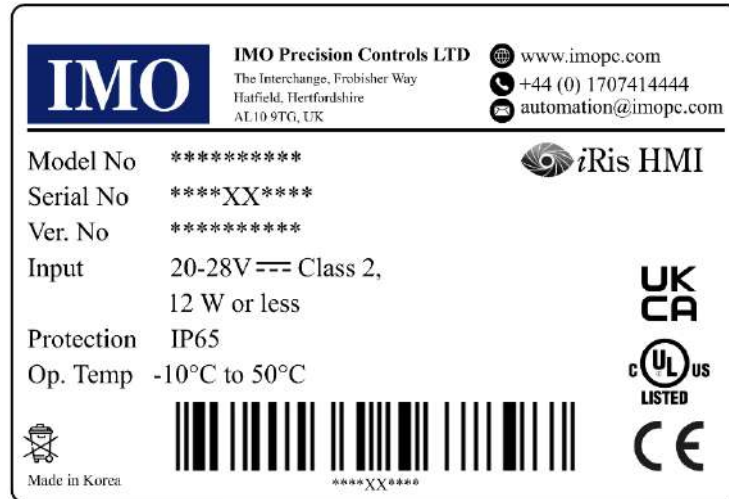

Copyright: IMO Precision Controls Ltd. 2026.02

- Please read related contents in this manual when you use IMO product and operate the product staying safe with appropriate handling.
- This manual should be stored in secured and appointed place so that it can be read in any needs.

IMO Worldwide Offices

IMO Precision Controls Limited

The Interchange
Frobisher Way
Hatfield, Herts AL10 9TG
United Kingdom

Tel: +44 (0)1707 414 444

Email: sales@imopc.com
Web: www.imopc.com

IMO Jeambrun Automation SAS

Parc de la Broye
14 rue du Chauffour
59710 ENNEVELIN
France

Tel: +33 (0)3 20 71 66 98

Email: imo-fr@imopc.com
Web: www.imojeambrun.fr

IMO Automazione

Via Belfiore 10,
50144 Firenze (FI)
Italia

Tel: +39 348 2286699

Email: imo-it@imopc.com
Web: www.imopc.it

IMO Automation LLC

Suite 112,
5910 Shiloh Road East
Alpharetta, GA 30005
USA

Tel: +1 404 476 8810

Email: sales-na@imopc.com
Web: www.imoautomation.com

IMO Canada

1B-701 Rossland Road East
Suite #608
Whitby, Ontario L1N 9K3
Canada

Tel: +1 905 799 9237

Email: sales-na@imopc.com
Web: www.imoautomation.com

IMO South Africa

16 Ezzo Road
Montague Gardens
Cape Town 7441
South Africa

Tel: +27 21 551 1787

Email: info@imopc.co.za
Web: www.imopc.co.za

IMO Pacific Pty Ltd

Unit 9, Dillington Pass
Landsdale
Perth WA 6065
Australia

Tel: +61 1300 34 21 31

Email: sales@imopacific.com.au
Web: www.imopacific.com.au



LinkedIn

Connect with us and follow
IMO Precision Controls for the
latest news, views and reviews

