



iOS - Remote I/O system

iOS/M12BDD-D2 12 Channel Digital (4 Input + 8 Output)



SPECIFICATIONS

	M12BDD-D2		M12BDD-D2
Inputs per Module (Commons)	4 (1 Common)	Sample Time (PLC Update Rate)	Min. 20mS - Determined by Configuration
Input Voltage Range	12/24 VDC	Terminal Type	Screw Type, Removable
Impedence	4.7k ohms	Storage Temp.	-40° to 85° Celsius
Peak Voltage	30 VDC	Operating Temp.	-10° to 60° Celsius
ON voltage level	10 VDC	Relative Humidity	5 to 95% Non-condensing
OFF voltage level	0-3 VDC	Dimensions WxHxD	17.5mm x 100mm x 120mm 0.69" x 3.94" x 4.72"
Outputs per Module	8 NPN (Trans)	Weight	210g (8.4 oz.)
Max Switching Power per O/P	600mA @ 30 VDC per channel, up to total of 3A.	Communications	Modbus/RTU (binary) RS-485 half duplex
Minimum Load	5 VDC, 10mA	Default Comms. Parameters	38400 baud, N, 8, 1, no h/s Default Modbus ID 1
Maximum Voltage	30VDC	Supported Modbus Commands	1,2,3,4,5,6,8,15,16
Required Power (Steady State)	45mA @ 24Vdc, typical		
Required Power (Inrush)	Negligible		
Isolation	2000Vac for 60 seconds (Input/Power & Input/Comms)		

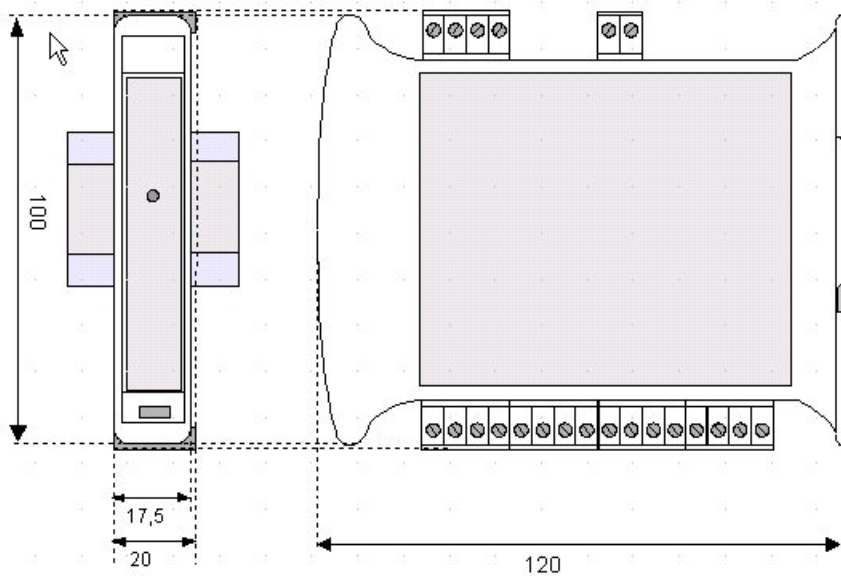

Note: Number of I/O terminal connections change with model type

WIRING – I/O

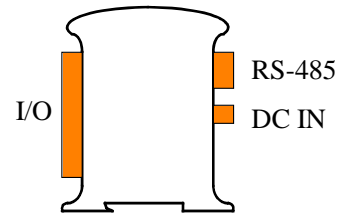
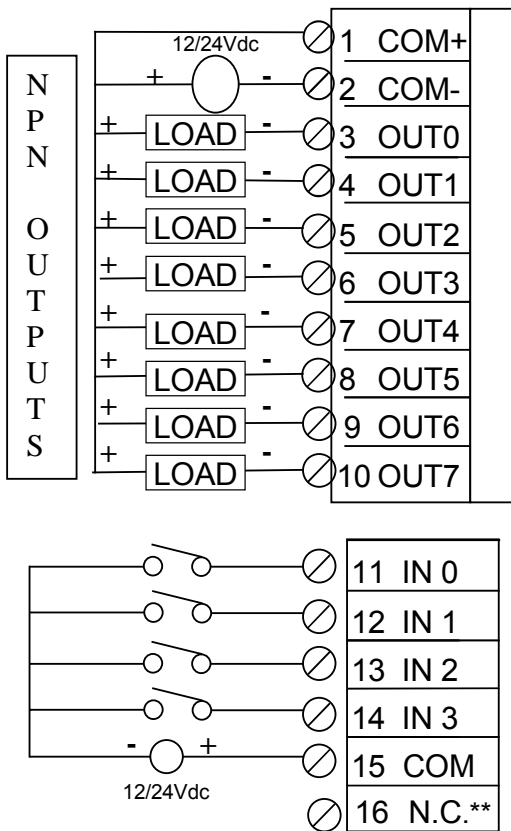

Pin #	12BDD-D2
1	COM +
2	COM -
3	OUT 0
4	OUT 1
5	OUT 2
6	OUT 3
7	OUT 4
8	OUT 5
9	OUT 6
10	OUT 7

11	INPUT 0
12	INPUT 1
13	INPUT 2
14	INPUT 3
15	COM
16	** Not Connected

WIRING – RS-485

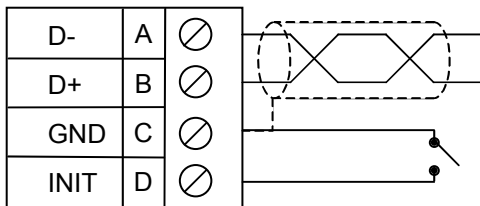

WIRING – DC IN

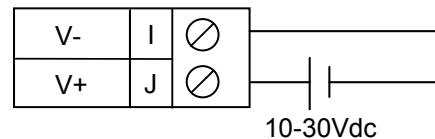

Notes:

Both ends of the RS-485 network should be terminated with a 100Ω, ¼W, 1% resistor. *i³* controllers feature dipswitches or jumpers, which enable appropriate termination if the *i³* is located on a network end.

Init default setup:

1. Install jumper between INIT and GND terminals of the RS-485 port.
2. Apply power to *iOS* unit.
3. Read parameter words to see current parameters.
4. Write changes if necessary.

The Init default RS485 settings are:

Modbus ID = 1
 Baud rate = 9600
 Parity = None
 Stop Bits = 1

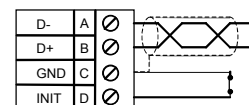

CONFIGURATION DATA

iOS configuration settings are mapped into Modbus register space. This configuration data may be modified with any Modbus/RTU Master device. For convenience, IMO Precision Controls have developed a variety of application files, which allow an *i³* Integrated Controller to act as the *iOS* configurator. Initial configuration of the *iOS* module should be done on an individual basis, since all modules are delivered with a factory default of Modbus ID 1. Once each module on the network has its own unique Modbus ID, further configuration adjustments can be made with the entire network powered.

All configuration parameters listed below (except 40012 Channel Enable) are stored in EPROM and for this reason they should not be constantly rewritten.

Configuration Parameters – Registers 40001 through 40013				
Modbus Register	Description	Min	Max	Default
40001-40005	Reserved			
40006	Communications Parameters	See Table		38.4kbaud, N, 8, 1, RTU Mode
40007	Modbus ID	1	255	1
40008	Rx/Tx Delay (in 2mS steps)	0	255	0mS
40009	Input Coils	Not Configuration Data – See I/O Data		
40010	Output Coils			
40011	Coils			
40012	Power Up/Safe	See Table		0
40013	Watchdog Timer (in 0.5s steps)	0	255	10 (5s)

Register 40006 (Communications Parameters) Bit Definition							
Bits 7-15	Bit 6	Bit 5	Bit 4	Bit 3	Bit 2	Bit 1	Bit 0
Unused	Mode	Parity		Data Bits	Baud Rate		
	0 = ASCII Mode	Value	Meaning	0 = 7 Data Bits	Value	Meaning	
		0	Mark		0	1200 baud	
	1 = RTU Mode	1	Even	1 = 8 Data Bits	1	2400 baud	
		2	Odd		2	4800 baud	
		3	Space		3	9600 baud	
					4	19200 baud	
					5-7	38400 baud	

Register 40012 (Power Up / Safe) Bit Definition									
Bits 12-15	Bit 11	Bit 10	Bit 9	Bit 8	Bit 4-7	Bit 3	Bit 2	Bit 1	Bit 0
Unused	Out 3	Out 2	Out 1	Out 0	Unused	Out 3	Out 2	Out 1	Out 0
	PowerUp Value					Safe Value			

INPUT / OUTPUT DATA

iOS Analog I/O utilizes both Modbus Registers (40001-40030) and Coils (1-11). It is possible to access all data using Registers only - Coils can be accessed through Register 40010.

The following tables list Modbus I/O data available.

I/O Register Data (Registers 40009)							
Modbus Register	Description	Access	Bits 1-4	Bit 9	Bit 10	Bit 11	Bit 12
40009	Input Coil Data	Read-only	*W.D.	In 0	In 1	In 2	In 3

*W.D. = Watchdog

I/O Register Data (Registers 40010)			
Modbus Register	Description	Access	Bits 9 - 16
40010	Output Coil Data	Read/Write	Out 0, 1, 2, 3, 4, 5, 6, 7

INSTALLATION / SAFETY

Warning: Remove power from the *i*³ controller, CAN port, and any peripheral equipment connected to this local system before adding or replacing this or any module.

- All applicable codes and standards should be followed in the installation of this product.
- Shielded, twisted-pair wiring should be used for best performance.
- Shields may be terminated at the module terminal strip.
- In severe applications, shields should be tied directly to the ground block within the panel.
- Use the following wire type or equivalent: Belden 8441.

When found on the product, the following symbols specify:



Warning: Consult user documentation.



Warning: Electrical Shock Hazard.