

SD1 Single Phase Motor Solution



The SD1 single-phase motor solution inverters follow the same parameter settings as of the other SD1 series inverters. However, single-phase motor SD1 has some additional parameters compared to the standard SD1 inverters.

For driving a single-phase motor, the following function code needs to be set as follows (see the red mark in the following table).

Function Code	Function Name	Detailed Illustration of Parameters	Setting Range	Default	
P00.00	Speed control mode	0: SVC 0 1: SVC 1 2: V/F control	0~2	2	⊙
P11.00	Phase loss protection	0x000~0x111 LED ones: 0: Input phase loss software protection disable 1: Input phase loss software protection enable LED tens: 0: Output phase loss protection disable 1: Output phase loss protection enable LED hundreds: 0: Input phase loss hardware protection disable 1: Input phase loss hardware protection enable	0x000~0x111	0x000	○

Solution 1: Single Phase Motor Control

1. Wiring

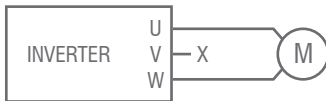

2. Function parameters setting

Function Code	Function Name	Detailed Illustration of Parameters	Setting Range	Default	
P02.04	Rated voltage of induction motor	0~1200V	0~1200	220V	⊙
P04.41	Single-phase drive mode	Ones: Motor control mode selection 0: Three-phase motor control. 1: Single-phase motor two-phase control 2: Single-phase motor single-phase control Tens: Voltage of the secondary winding (V phase) reverse while single-phase motor two-phase control 0: Not reversed; 1: Reversed	0x00~0x12	0x02	⊙

SD1 Single Phase Motor Solution



Solution 2: Two Phase Motor Control (remove start and run capacitor of motor)

1. Wiring

If the single-phase pump cannot be started, the two-phase control method must be used, and the start-up and running capacitors (if any) of the motor must be removed. The figure below shows the internal wiring of the single-phase motor. In the figure, L1, L2, C1, and C2 indicate the running winding, start-up winding, running capacitor, and start-up capacitor.

When the motor speed exceeds 75% of the rated speed, the start-up capacitor is switched off.

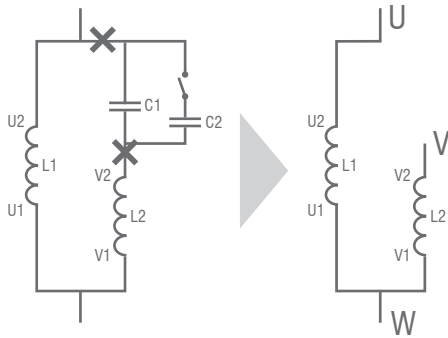

U1 and V1 are the common terminals of the windings. Connect them to the output terminal W of the inverter. Connect U2 to the output terminal U of the inverter. Connect V2 to the output terminal V of the inverter.

2. Motor Direction

You can change the motor's outlet V1 and V2 or change the V phase voltage phase through the ten bits of the function code P04.41 to change the direction of the motor.

3. Function parameters setting

Function Code	Function Name	Detailed Illustration of Parameters	Setting Range	Default	
P04.41	Single-phase drive mode	Ones: Motor control mode selection 0: Three-phase motor control. 1: Single-phase motor two-phase control 2: Single-phase motor single-phase control Tens: Voltage of the secondary winding (V phase) reverse while single-phase motor two-phase control 0: Not reversed; 1: Reversed	0x00~0x12	0x01	⊙
P04.42	Voltage ratio of V and U while single-phase motor two-phase	0.00~2.00	0.00~2.00	1.00	○
P17.38	Main winding current of single-phase motor two-phase	0.0~100.0A	0.0~100.0A	0.0A	●
P17.39	Secondary winding current of single-phase motor two-phase	0.0~100.0A	0.0~100.0A	0.0A	●
P02.04	Rated voltage of asynchronous motor	0~1200V	0~1200V	200V	⊙