

TKB48B..

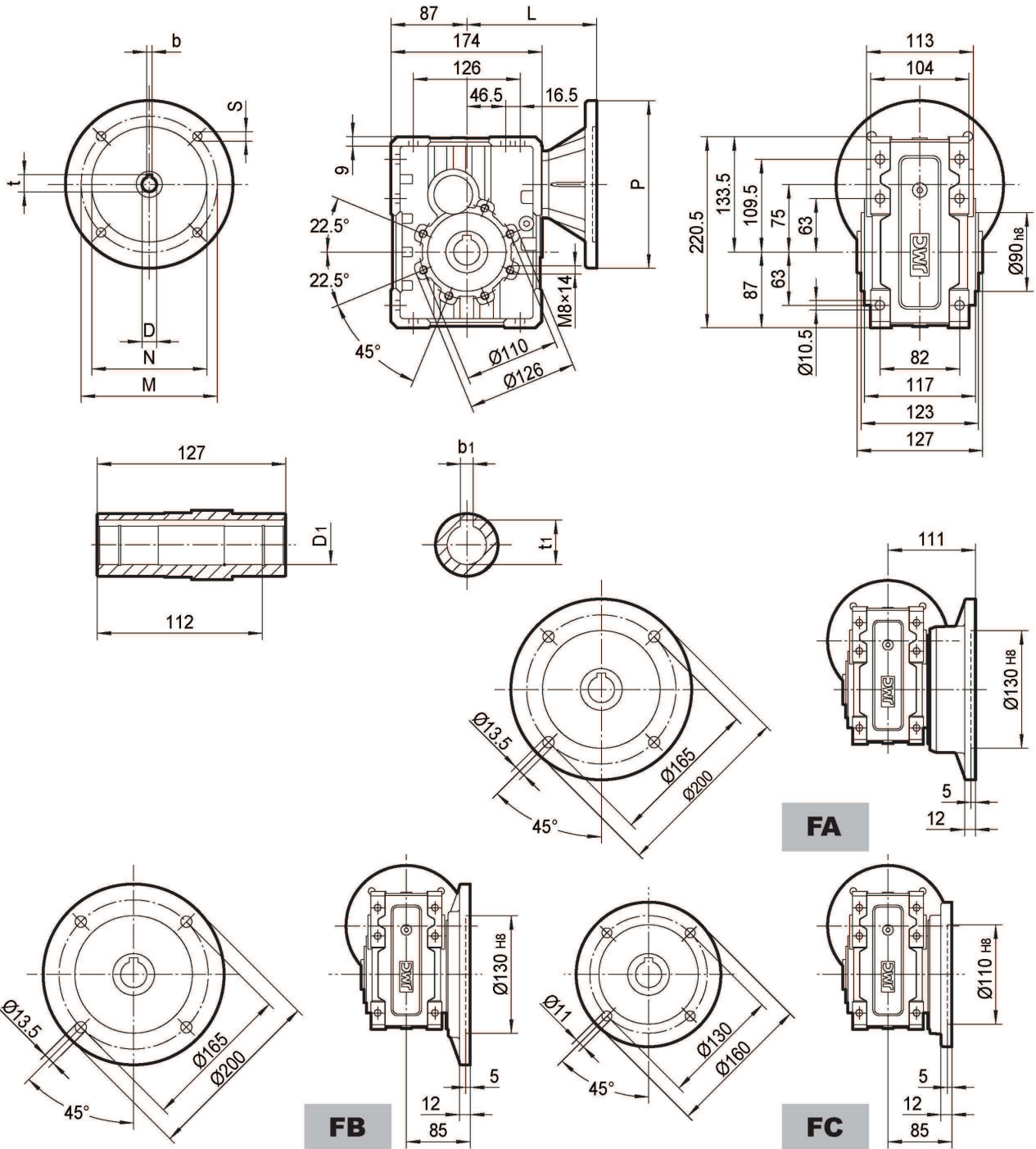

IEC	D <sub>E8</sub>	b	t	P	M	N	S	T	L	D <sub>1</sub> H <sub>8</sub>	b <sub>1</sub>	t <sub>1</sub>
71B5	14	5	16.3	160	130	110	9	4	146	28*	8*	31.3*
80B5	19	6	21.8	200	165	130	11	4	166	30	8	33.3
80B14	19	6	21.8	120	100	80	7	4	166	35*	10*	38.3*
90B5	24	8	27.3	200	165	130	11	4	166	* Only on request		
90B14	24	8	27.3	140	115	95	9	4	166			
100/112B5	28	8	31.3	250	215	180	13.5	4.5	176			
100/112B14	28	8	31.3	160	130	110	9	4.5	176			

Weight without motor  
 ≈ 9.5 kg

**TKB48C..**

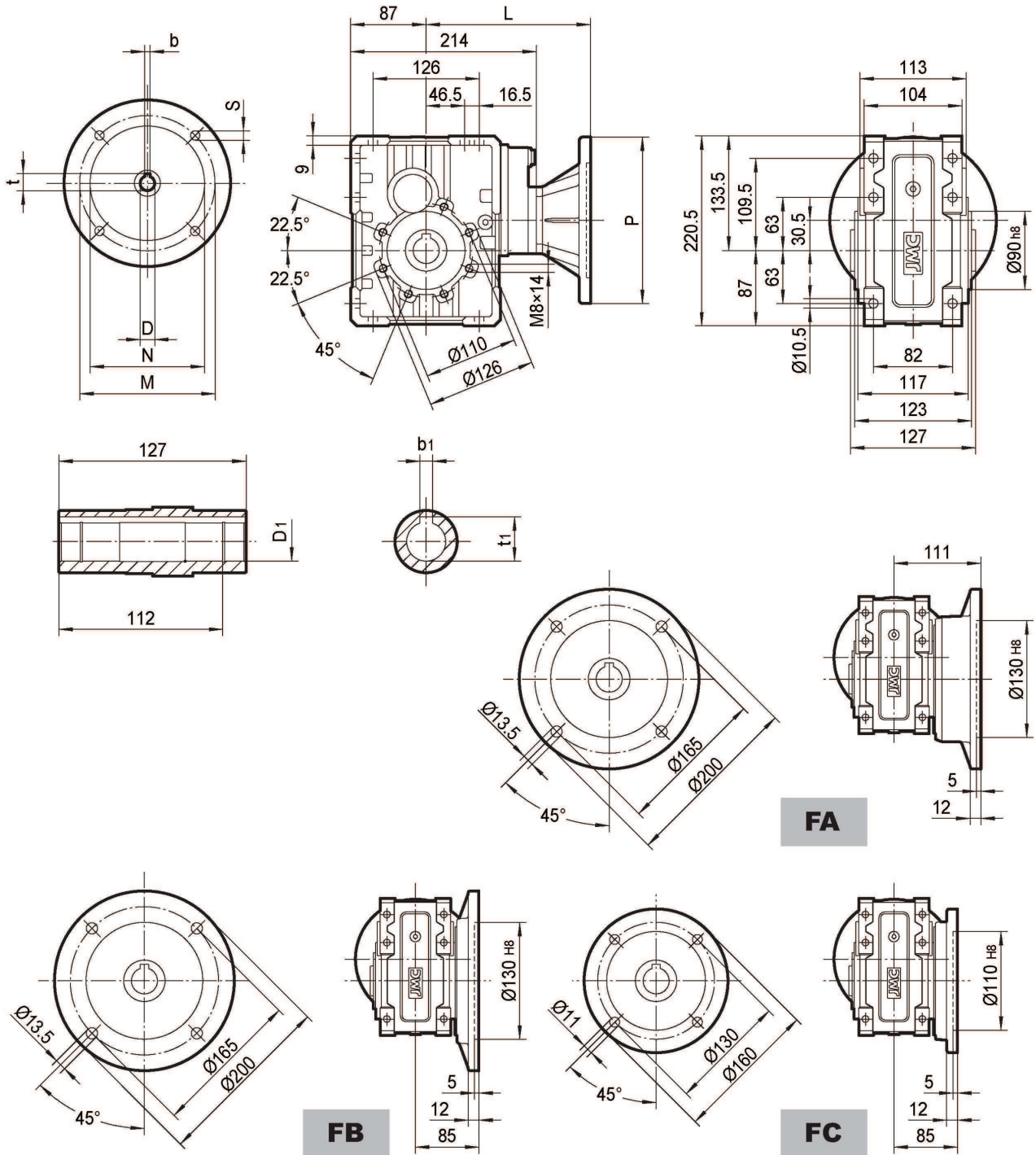

IEC	D <sub>E8</sub>	b	t	P	M	N	S	T	L	D <sub>1</sub> H <sub>8</sub>	b <sub>1</sub>	t <sub>1</sub>
63B5	11	4	12.8	140	115	95	9	4	179	28*	8*	31.3*
71B5	14	5	16.3	160	130	110	9	4	186	30	8	33.3
80B5	19	6	21.8	200	165	130	11	4	206	35*	10*	38.3*
80B14	19	6	21.8	120	100	80	7	4	206	* Only on request		
90B5	24	8	27.3	200	165	130	11	4	206			
90B14	24	8	27.3	140	115	95	9	4	206			

Weight without motor  
≈ 10.8 kg