

7. OUTLINE DIMENSION SHEET

7.1 TKM.. Outline Dimension

TKM28B..

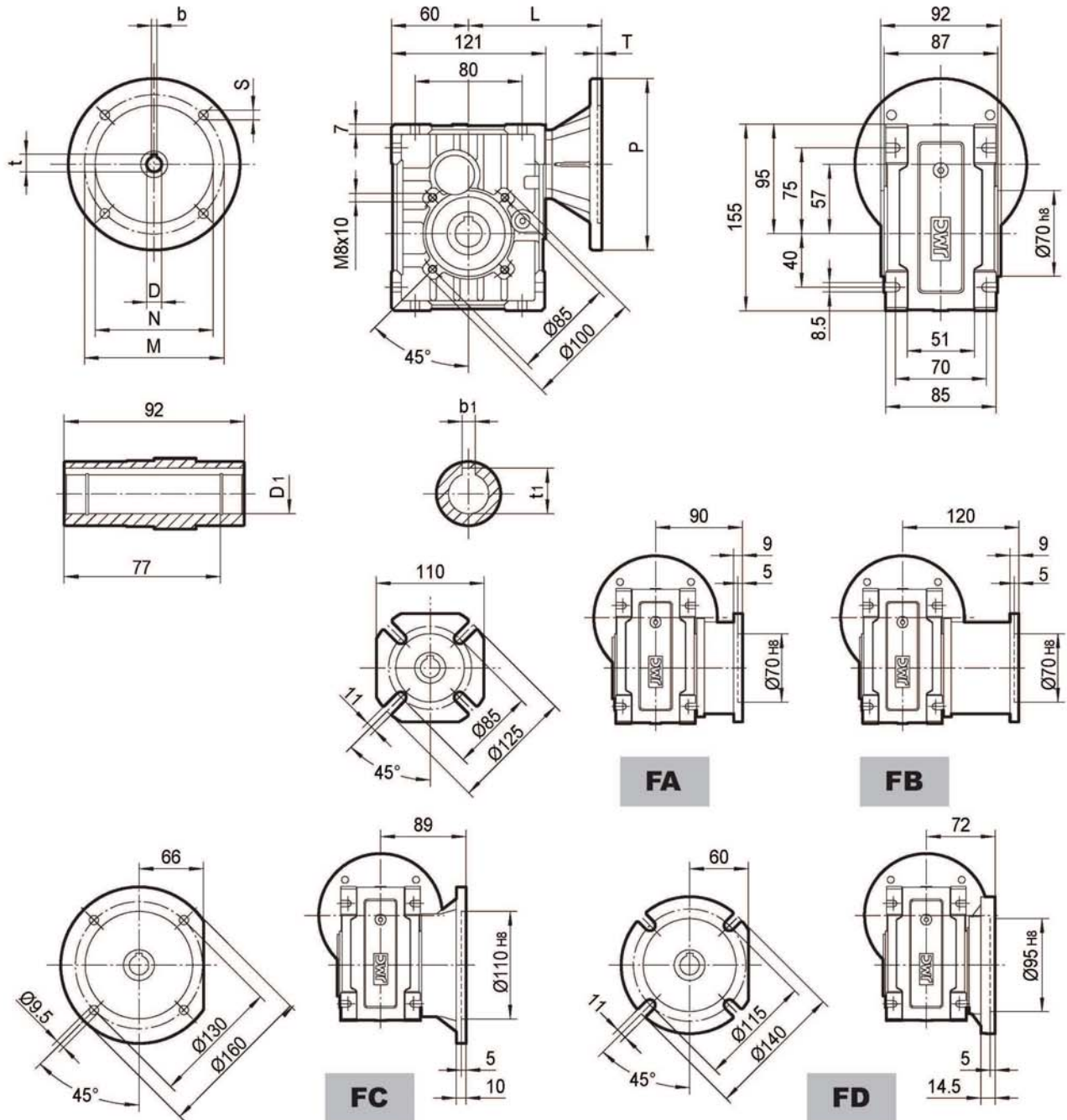

IEC	DE8	b	t	P	M	N	S	T	L	D1 H8	b1	t1
63B5	11	4	12.8	140	115	95	9	4	106	20*	6*	22.8*
71B5	14	5	16.3	160	130	110	9	4	113	24*	8*	27.3*
71B14	14	5	16.3	105	85	70	7	4	113	25	8	28.3
80B5	19	6	21.8	200	165	130	11	4	133	* Only on request		
80B14	19	6	21.8	120	100	80	7	4	133			
90B5	24	8	27.3	200	165	130	11	4	133			
90B14	24	8	27.3	140	115	95	9	4	133			

Weight without motor
≈ 4.2 kg

TKM28C..

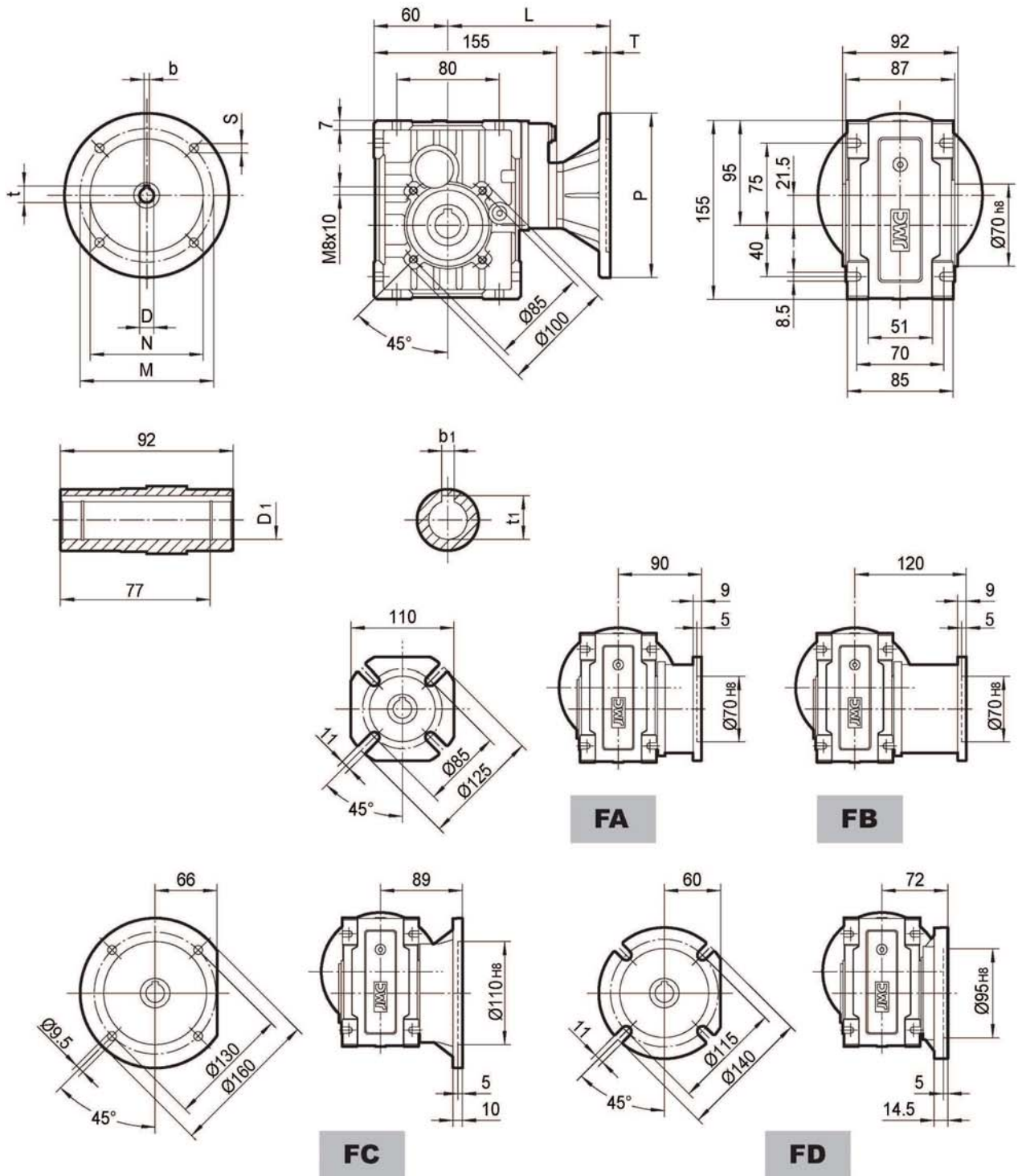

IEC	D _{E8}	b	t	P	M	N	S	T	L	D _{1 H8}	b ₁	t ₁
63B5	11	4	12.8	140	115	95	9	4	140	20*	6*	22.8*
71B5	14	5	16.3	160	130	110	9	4	147	24*	8*	27.3*
71B14	14	5	16.3	105	85	70	7	4	147	25	8	28.3
* Only on request												

Weight without motor
≈ 5 kg