



**SMART MOTOR DEVICES**

<https://www.smd.ee>

**STEP MOTOR DRIVER  
SMD-2.8DIN**

*manual*  
**SMDDIN.28.001**

**2019**



## 1. Product designation

Step motor controller SMD-2.8DIN is an electronic device designed to operate with 2 or 4-phase stepper motor with maximum current per phase up to 2.8 Amp.

## 2. Functions and possibilities

The motion control is carried out by logic signals "Step", "Direction" and "Enable". The motor's shaft moves one angle step (or microstep) as the driver receives one "Step" signal. One step (or microstep) executes as the front edge of the voltage pulse on the "STEP" input. Rotation direction depends on the voltage level and switches by changing voltage level on the "DIR" input. The motor can be urgently stopped by the active signal on the "EN" input. Maximum phase current and microstepping mode are set by switches at the driver frame.

Output signal FAULT is provided to control current state of the driver. Under normal operation conditions resistance between terminals «FAULT+» and «FAULT-» is about 150 – 160 Ohm. In case of alarm resistance between the terminals tends to infinity.

## 3. Technical characteristic

Table 1.

<b>Common characteristics:</b>	
Maximum output current per phase, Amp	2.8
Minimum output current per phase, Amp	1.3
Microstepping	1/1, 1/2, 1/4, 1/8, 1/16, 1/32, 1/64, 1/128, 1/256
Power supply, VDC (stabilized)	12...24
Maximum overall dimensions, mm	116x100x23
<b>Inputs STEP, DIR, ENABLE</b>	
High voltage level, VDC	5...12*
Low voltage level, VDC	0...1
Input STEP resistance, kOhm, no less	3
Inputs DIR and ENABLE resistance, kOhm, no less	1
Input current of control input STEP, mA	1,4...4
Input current of control inputs DIR и ENABLE, mA	4...12
<b>Output «FAULT» parameters</b>	
Signal type	Opto-coupler output
Maximum voltage, VDC	20
Maximum load current, mA	100
Resistance at close contact, Ohm, no more	100

\*It is possible to apply 24VDC high level voltage on condition of using additional current limiting resistors – 3 kOhm for STEP input and 1 kOhm for the rest inputs.

### Environmental Conditions:

Ambient Temperature: 0...+40°C

Humidity: 90% RH or less upon condition +25°C

Condensation and freezing: none

Pressure: 650...800 mm of mercury

**Attention:** when operating with high inertia loads, the output shaft of the motor can be turned by external force if it decelerates abruptly. In such cases, and also in case of long time forced shaft rotations, the motor generates back emf, which can damage output stages of the drive. In order to prevent driver to be damaged it is recommended to prevent abrupt decelerations on the motor, forced rotations of motor shaft and disconnecting motor phases or driver power supply during motor operation.



## 4. Connection scheme

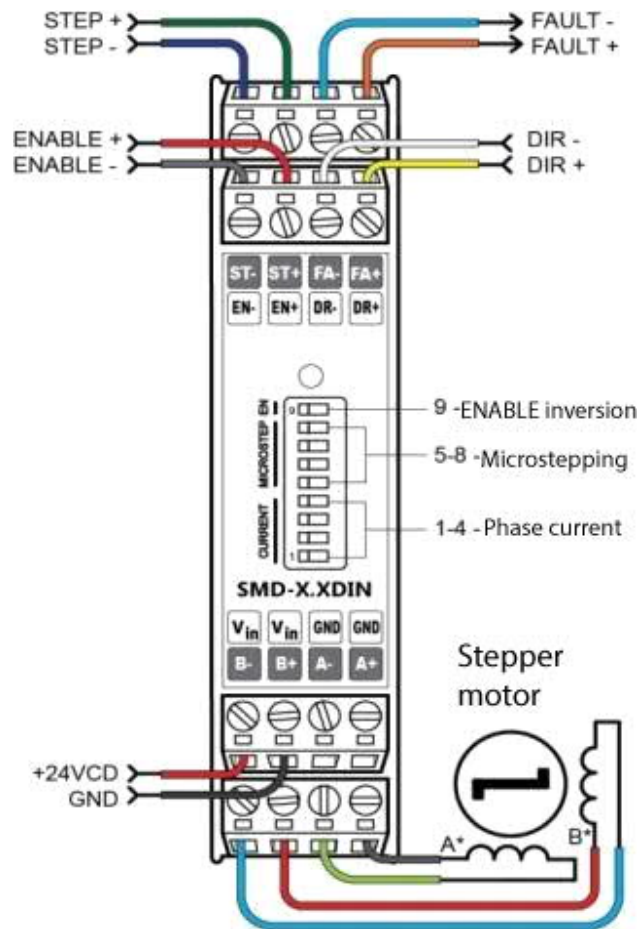

## 5. Dimensions

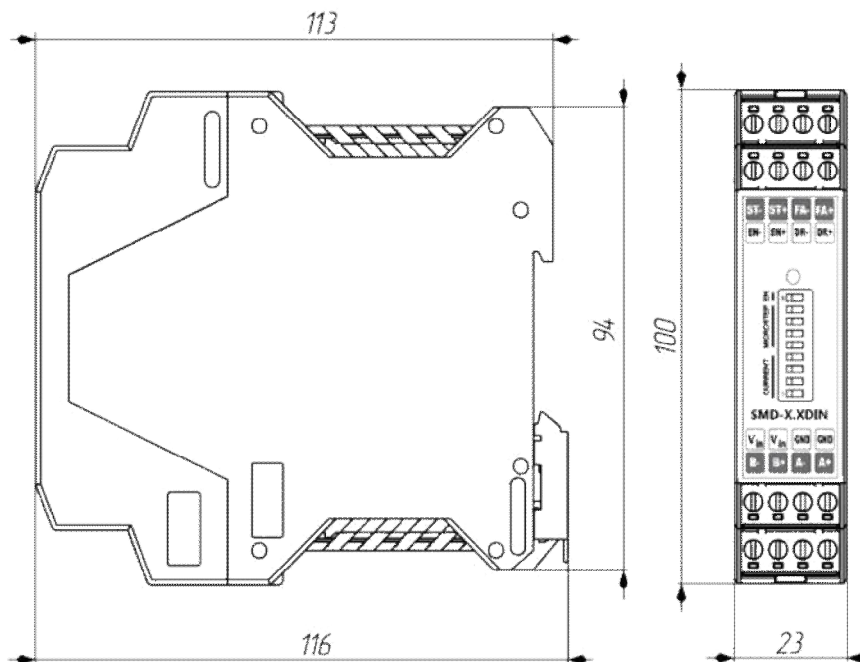



## 6. Setting of phase current and

S1	S2	S3	S4	Phase current, A
off	off	off	off	1.3
on	off	off	off	1.4
off	on	off	off	1.5
on	on	off	off	1.6
off	off	on	off	1.7
on	off	on	off	1.8
off	on	on	off	1.9
on	on	on	off	2.0
off	off	off	on	2.1
on	off	off	on	2.2
off	on	off	on	2.3
on	on	off	on	2.4
off	off	on	on	2.5
on	off	on	on	2.6
off	on	on	on	2.7
on	on	on	on	2.8

## 7. Setting of microstepping mode

S5	S6	S7	S8	Microstepping
off	off	off	off	1/1
on	off	off	off	1/2
off	on	off	off	1/4
on	on	off	off	1/8
off	off	on	off	1/16
on	off	on	off	1/32
off	on	on	off	1/64
on	on	on	off	1/128
off	off	off	on	1/256
on	off	off	on	1/256
off	on	off	on	1/256
on	on	off	on	1/256
off	off	on	on	1/256
on	off	on	on	1/256
off	on	on	on	1/256
on	on	on	on	1/256

## 8. Enable signal inversion

S9	Enable inversion
Off	Not inverted
On	inverted

## 9. Delivery in complete sets

Steptomotor driver SMD-2.8DIN  
Manual SMDDIN.28.001

1 pcs  
1 pcs

## 10. Warranty

**Any repair or modifications are performed by the manufacturer or an authorized company.**

The manufacturer guarantees the failure-free operation of the controller for 12 months since date of sale when the operation conditions are satisfied.

The manufacturer sales department address:  
Smart Motor Devices OÜ,  
Tallinn Science Park Tehnopol, Akadeemia tee 21/6, 12618, Tallinn, Estonia.,  
Phone: + 372 6559914,  
e-mail: [mail@smd.ee](mailto:mail@smd.ee)  
url: <https://smd.ee>

Date of sale: