



SMART MOTOR DEVICES

<http://www.smd.ee>

Stepper motor SM8680 with integrated driver SMD-4.2 mini

PASSPORT
SM8680/SMD.42.000

1. Product designation

This device is a stepper motor SM8680 with an integrated control unit SMD-4.2 mini. Stepper motor is intended for transformation of control signals in angular movement of the rotor with its fixation in the given position without feedback devices. Integrated control unit SMD-4.2 mini is an electronic device mounted on the motor SM8680 housing and is intended for this motor control. The driver can be used with others 4 and 2-phases stepper motors with current per phase up to 4.2Amp.

2. Technical characteristics

2.1. Stepper motor SM8680 technical characteristics

Table 1

Motor phase current, Amp	4.2
Phase resistance, Ohm	0.8
Phase inductance, mH	3.5
Holding torque, kgf·cm ¹	45
Rotor inertia, g·cm ²	1400
Step angle, °	1.8
Max. radial force (20 mm from the flange), N	220
Max. axial force, N	60
Shaft radial play, no more, mm	0.02
Shaft axial play, no more, mm	0.08
Step angle accuracy	±5% relative to the whole step
Temperature Rise, °C	80
Average resource, hours	20000
Number of leads	8

¹ Holding torque – the motor is powered but doesn't rotate

Motor wiring

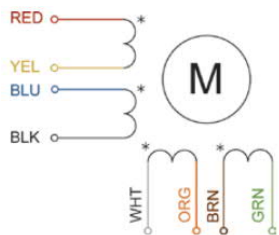

Img.1. SM8680 wiring

Series connection

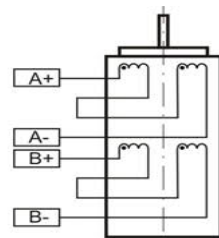

Parallel connection

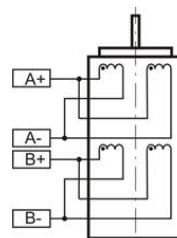

Img.2 Connection scheme

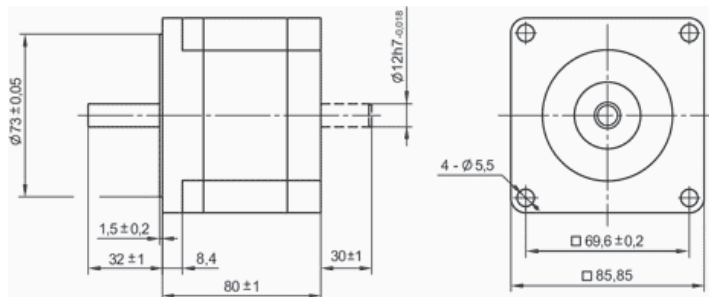

Img.3. Dimensions of stepper motor SM8680

The scheme at the image 7 present the logic signals with EN active at low level voltage signal (SW3 is ON).

1. If use the internal signal source:
 - 6.1 Turn the switch SW3 to "ON".
 - 6.2 Activate the internal pulse generator by turning the switch SW4 to "ON".
 - 6.3 Turn On the driver power supply. The LED "READY" should glow continuously.
 - 6.4 Using the internal potentiometer «SPEED» adjust the motor rotation speed.

Attention: In order to prevent a casual closing of electronic components at the driver circuit board, the potentiometer "SPEED" should be adjusted with a screwdriver PH1 with dielectric drive blade or with a special plastic screwdriver for tuning radio equipment.

- 6.5 Switch SW4 to "Off" for the motor stop and holding mode.
 - 6.6 Switch SW3 to "Off" for the motor stop and deenergizing the motor phases.
2. Turn off the driver power supply after work is finished.

6. Operating conditions of SM8680 stepper motor and integrated control unit SMD-4.2 mini

Stepper motor is intended for continuous operating.
 Ambient temperature – (0...+50)°C
 Humidity 90%
 Pressure (650...800) mm of mercury

7. Delivery in complete sets

SM8680 stepper motor with the control unit SMD-4.2 mini	1pcs.
Manual SM8680/SMD.42.000	1pcs.

8. Warranty

Any repair or modifications are performed by the manufacturer or an authorized company.

The manufacturer guarantees the failure-free operation of the controller for 12 months since date of sale when the operation conditions are satisfied – section 7.

The manufacturer sales department address:

Smart Motor Devices OÜ, Tallinn Science Park Tehnopol, Mäealuse st. 4,
 Tallinn 12618, Estonia,
 Phone: + 372 6559914,
 e-mail: sale@smd.ee
 url: http://smd.ee

Date of sale:

2.2. SMD-4.2 mini technical characteristics

Table 2

Output current per phase, Amp	4.2
Power supply voltage, VDC stabilized	12...48
Inputs high voltage level, VDC	5 - 24
Please, connect current-limiting resistance when use high level voltage more, than 5VDC: 1KOhm for 12VDC, 2KOhm for 24VDC (power >0,5W).	
Inputs low voltage level, VDC	0...1
Logic signal current, mA	10...16
Minimum "Step" pulse length, µs	3
Direction setting time, µs	5
Frequency adjusting range of an internal generator, Hz (approximately)	70...1200
Overall dimensions, mm	85x85x31

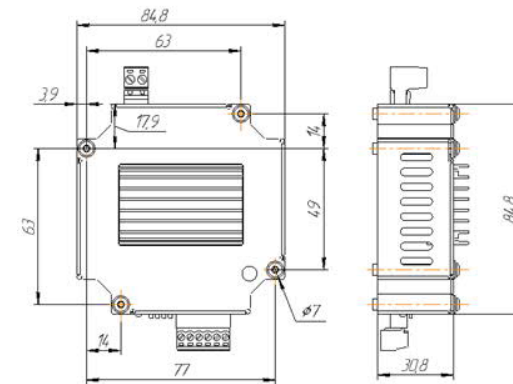

Img. 4. Dimensions of a built-in steppmotor driver SMD-4.2 mini.

3. Construction of SMD-4.2 mini

SMD-4.2 mini is designed as a circuit plate with electronics elements, in a case with a radiator. Besides electronic components, there are indicating and control elements, connection terminals and connectors on the board:

- terminal screws for power supply, stepper motor and control circuit connection;
- LED "READY" for power supply indication;
- switches SW1 and SW2 for microstepping mode setting;
- switch SW3 for signal EN inversion;
- switch SW4 for using of an internal pulses generator instead of signals "STEP";
- internal potentiometer "SPEED" for frequency adjusting of the internal generator.

SMD-4.2 mini support two operation modes: with external pulses generator and as a standalone unit with internal pulses generator. The operation mode is set by the switch SW4.

Using an external pulses generator SMD-4.2 mini driver receives logic signals “Step”, “Direction” and “Enable” and convert them into motor commutation. The motor shaft moves one angle step (or microstep) as the driver receives one “Step” signal. One step (or microstep) executes as the front edge of the voltage pulse at the “Step” input. Rotation direction depends on the voltage level and switches by changing voltage level at the “DIR” input. The motor can be deenergized and urgently stopped by the active signal at the “EN” input.

In the standalone operation mode SMD-4.2 mini uses the internal pulses generator, motion speed is adjusted by the potentiometer “SPEED”.

4. Assembly and connection

Please, learn this manual carefully before connection and assembly.

Please wire just when power is off. Do not attempt to change wiring while the power is ON. Please provide a reliable contact in connection terminals. During wiring, please, observe the polarity and wire management. Make a point of observing the motor phases polarity.

ATTENTION: For the optimal cooling effect perform assembling of the driver such a manner, that the radiator ribs were located upright.

Please, connect current-limiting resistance when use high level voltage more, than 5VDC: 1KOhm for 12VDC, 2KOhm for 24VDC.

5. Before starting

3. Make sure the power supply is turned off.
4. If necessary, attach the driver to the stepper motor.
5. Provide the motor phases connection according Img.1 and Img.2.
6. Chose a suitable microstepping mode and set micro switches SW1 and SW2 according to the table 3.

Table 3.

	1	1/2	1/4	1/16
SW1	On	On	Off	Off
SW2	On	Off	On	Off

7. If use an external logic signals source:

- 5.1 Turn the switch SW4 to “OFF”.
- 5.2 Connect a logic signals source according Img.5 and Img.6.
- 5.3 Turn the switch SW3 according required voltage level of the signal “EN”:
 - «On» - “EN” is active when signal is low voltage level,
 - «Off» - “EN” is active when signal is high voltage level.
- 5.4 Turn On the driver power supply. The LED “READY” indicates power supply as a continuous glow.
- 5.5 Turn On the power supply of a logic signals source.
- 5.6 To control the stepper motor set the required sequence of logic signals “STEP” (motor steps), “DIR” (rotation direction), “EN” (enable motion) according to the scheme at the image 7. One step (or microstep) executes as the front edge of the voltage pulse on the “STEP” input. Direction switches by changing voltage level on the “DIR” input. The motor stops and windings are deenergized as the front edge of the signal at the “EN” input.

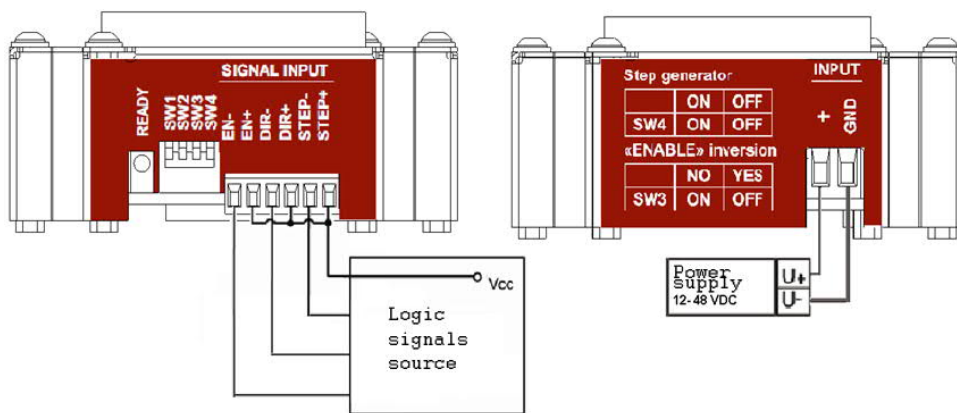

Img.5. SMD-4.2 mini connection scheme

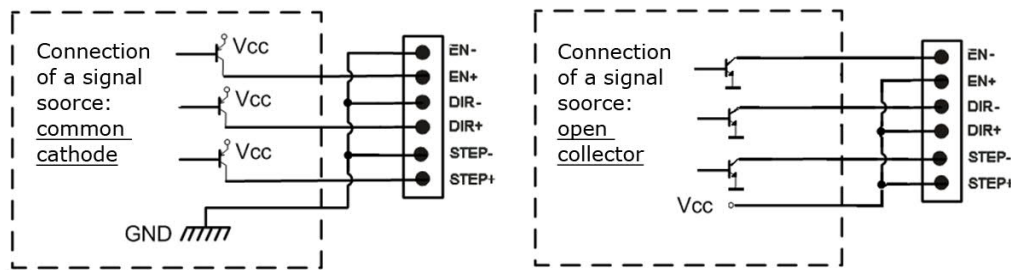

Img.6. Logic signals connection examples

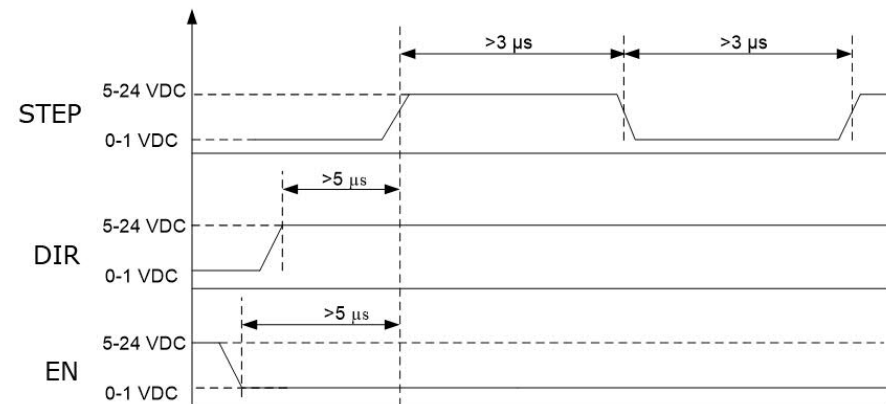

Img.7. STEP, DIR, EN signals.