

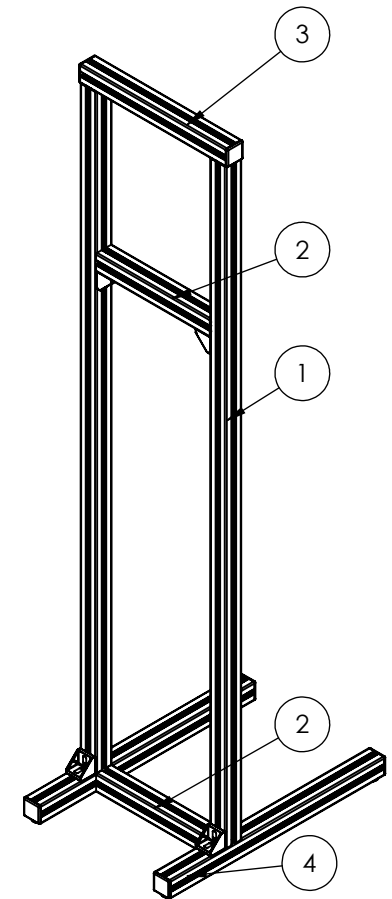

No. ARTICLE	NUMERO DE PIECE	QTE
1	45x45L_1655	2
2	45x45L_319	2
3	45x45L_409	1
4	45x45L_600	2



A	Création				
REV.	DESCRIPTION	DATE	DESSINE	APPROUVE	
		Technic-Achat Engineering 05 57 99 01 72		NOM DU DESSIN: ARMCH_40A	
MATERIAU :	Dimensions en mm	TAILLE	DESSIN n°:		
	Tolérances usinage : ISO 2768 mK	A4			
FINITION :	Ra si non spécifié :	ECHELLE : 1:15		PAGE 1 sur 1	
AUTEUR :	Surfaçage : 1,6 µm Contournage : 3,2 µm Tournage : 1,6 µm				